



**BRETFORD**

**LAP30EBA**

**LAP30EFR**

**NOTEBOOK CART ASSEMBLY**

**Assembly Instructions for:  
INTERIOR E-UNIT  
REPOSITIONING / REPLACEMENT  
AND  
TIMER INSTALLATION**

**Parts List**

Qty.	Part No.	Description
1	LAP30EBA	Cart Assembly, e-units at back
	LAP30EFR	Cart Assembly, e-units at front

**Tools Required**

Philips screwdriver

**MAXIMUM WEIGHT OF ACCESSORIES  
ON TOP OF CART: 25 LBS.**

**NOTE:**

**UNPLUG CART POWER CORDS FROM  
POWER SOURCE BEFORE STARTING**

**E-UNIT REPOSITIONING:  
'FRONT TO REAR'**

**CAUTION: RISK OF ELECTRICAL SHOCK.  
DO NOT PLUG INTO ANOTHER  
RELOCATABLE POWER TAP.**

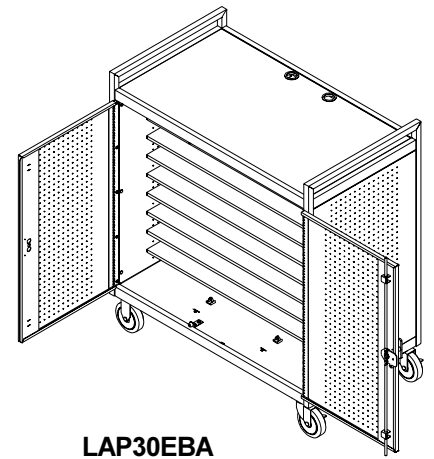

**LAP30EBA**

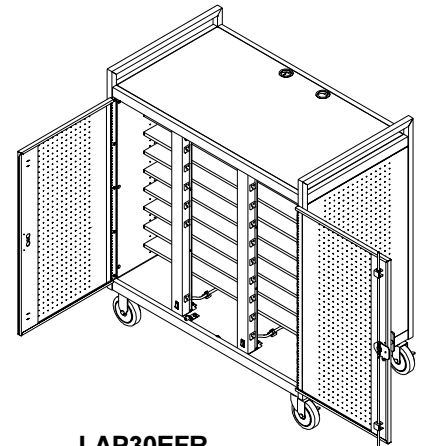

**LAP30EFR**

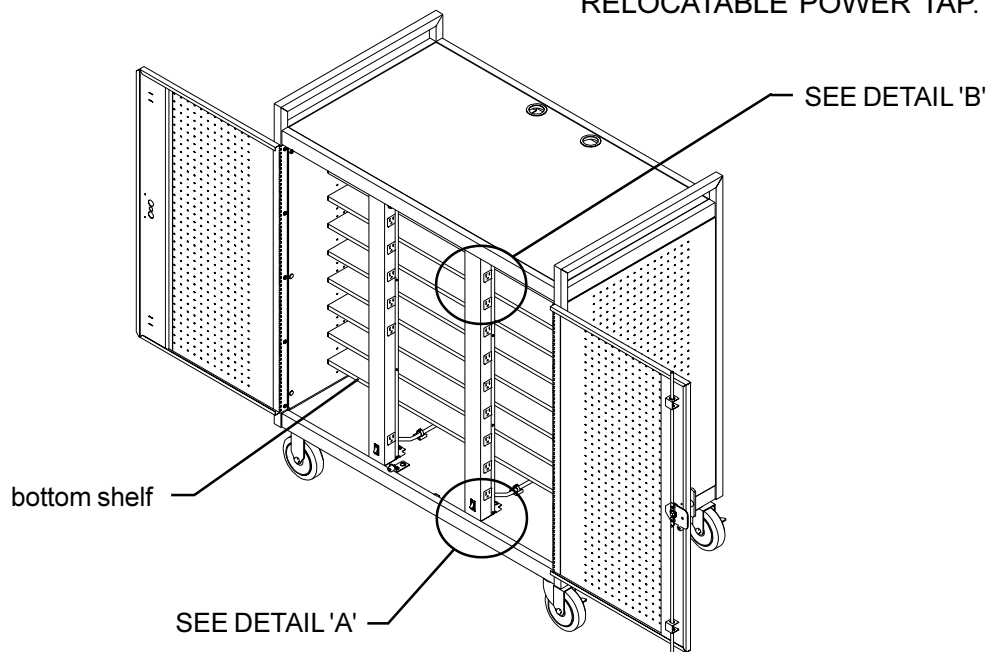

**Step 1**

Open both front doors of cart to access E-Units. Unwind any length of E-Unit power cord remaining on the exterior rear panel cord wrap brackets. From underneath the bottom shelf (see Front View), carefully unclip the power cords from the 4 clips located at the bottom panel of the cart. Loosen the screw holding the E-Unit bracket assembly and remove all 4 bracket assemblies (see DETAILS 'A' and 'B').

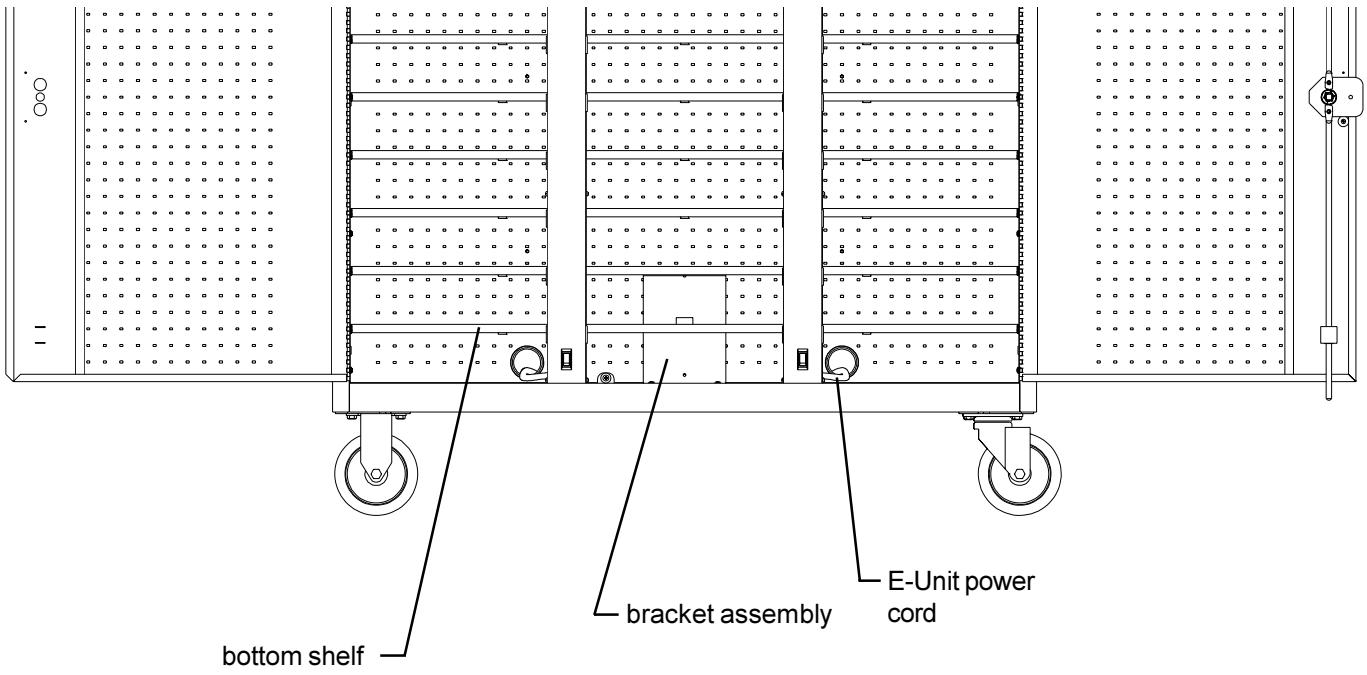

**Front View**

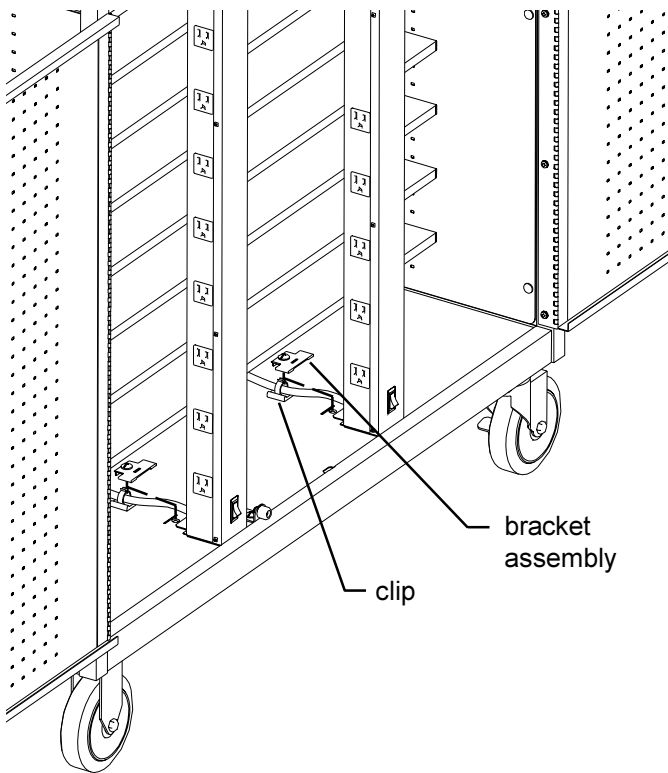

**DETAIL 'A'**

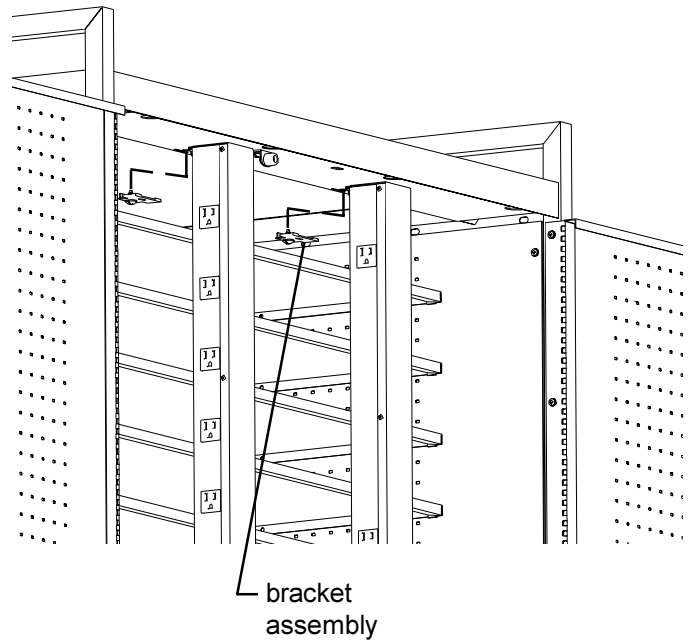

**DETAIL 'B'**

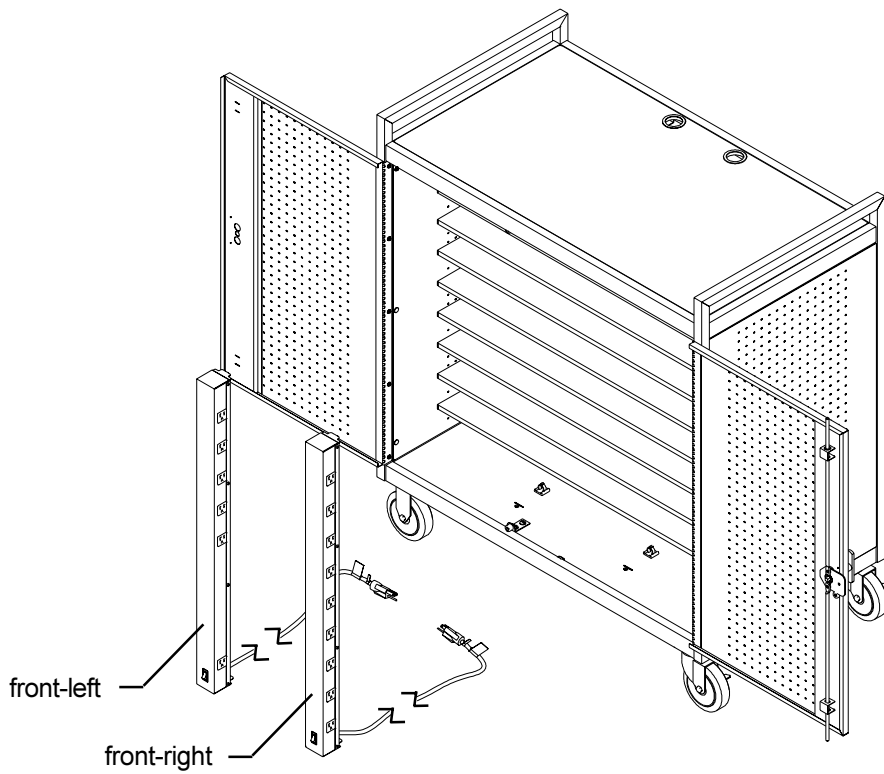

### Step 2

Remove **front-left** E-Unit by gripping the top and tilt it side ways until it clears the underside of the cart interior shelf channel and set it aside.

Remove **front-right** E-Unit by gripping the top and tilt it side ways until it clears the underside of the cart interior shelf channel and set it aside.

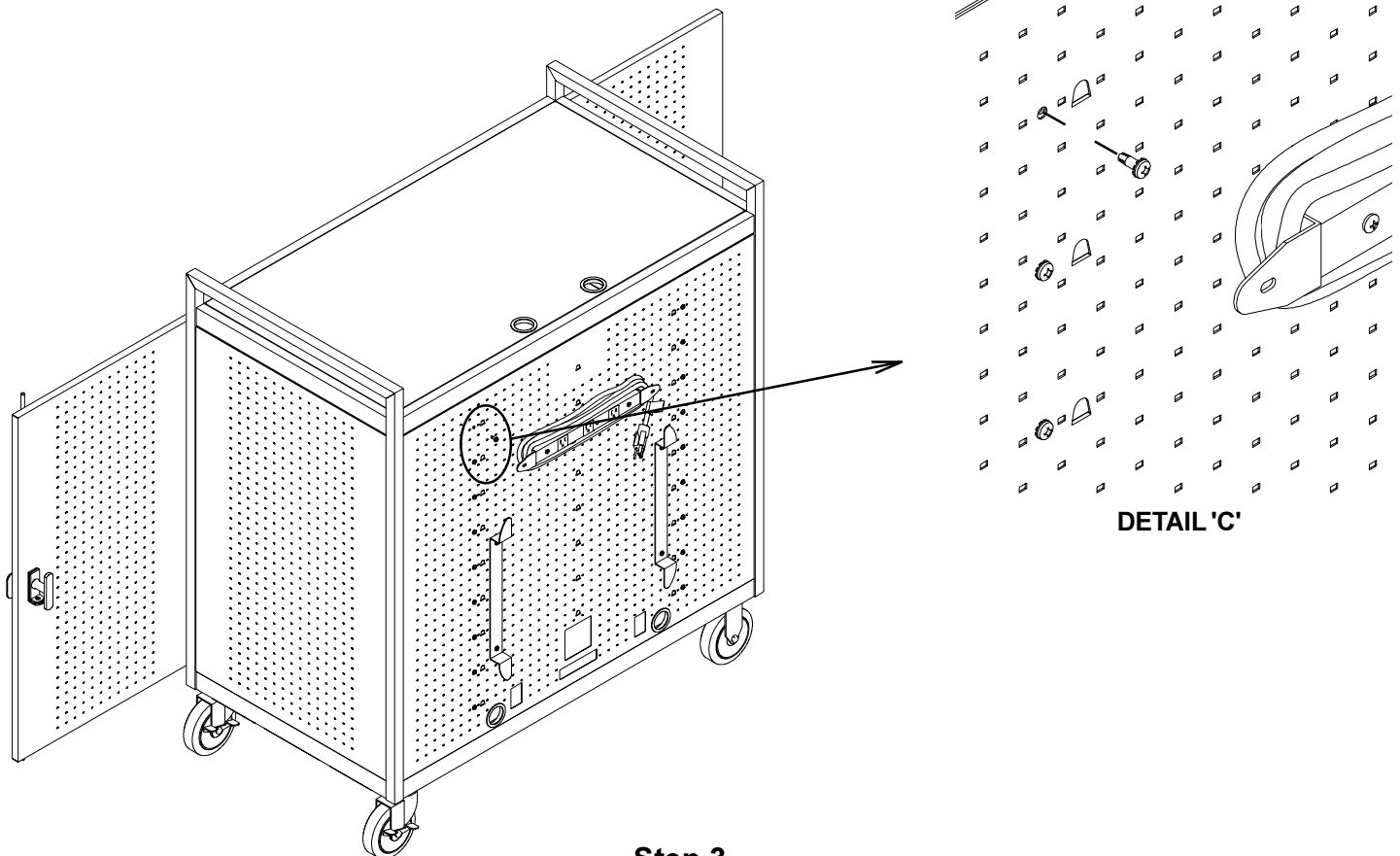

### Step 3

Remove 18 screws (2 per shelf) from rear panel that secure the 9 interior shelves (see DETAIL 'C').

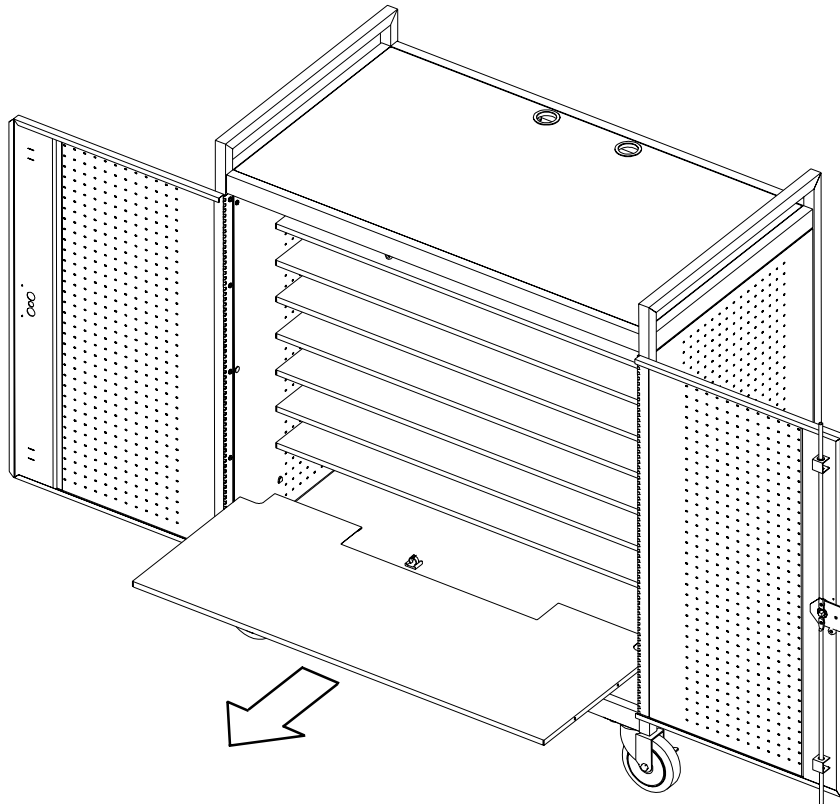
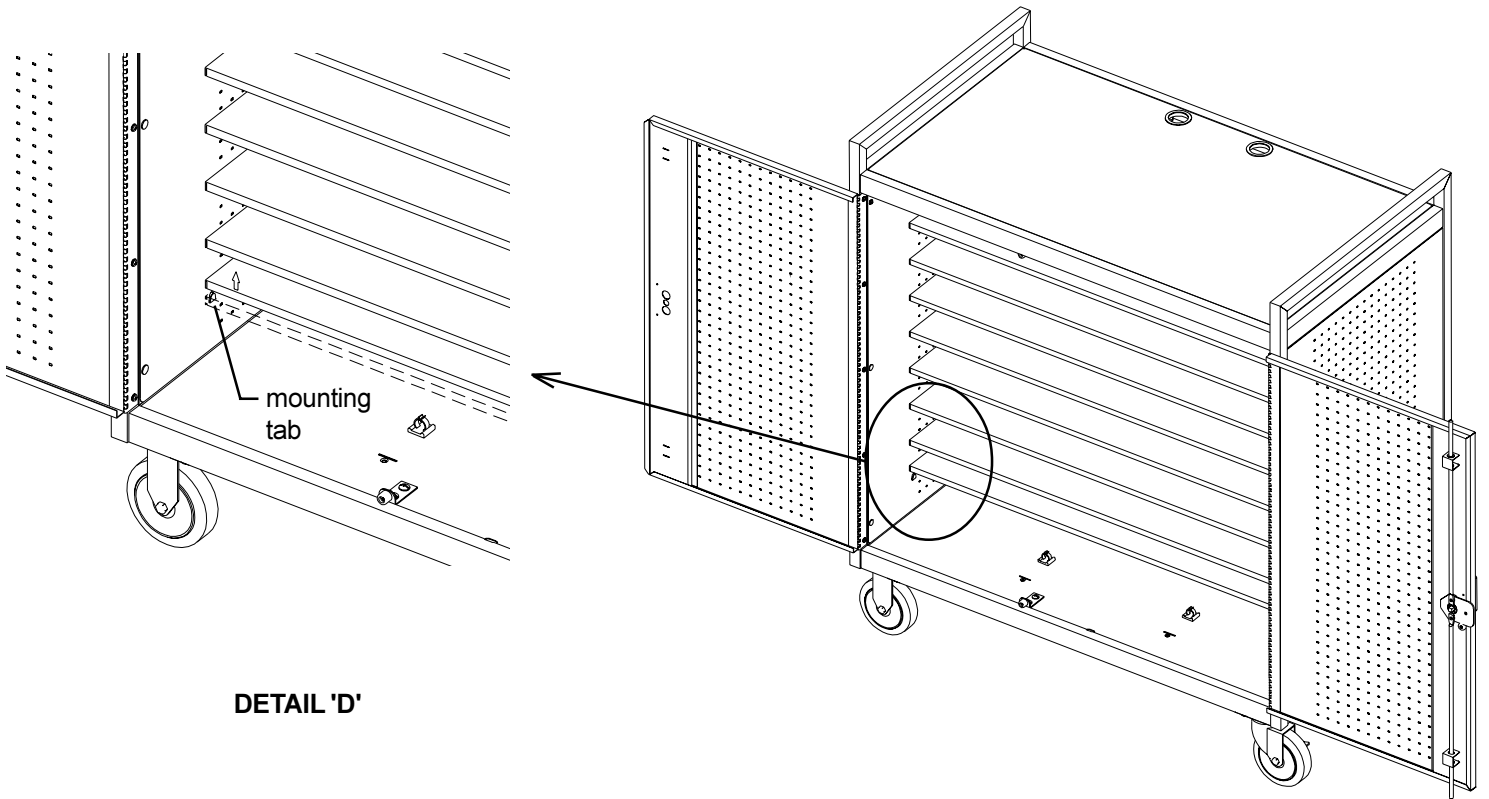

#### Step 4

Remove each interior shelf by carefully pushing upward (to release shelf from mounting tabs) shown in Detail 'D', then carefully sliding out. Set each shelf aside.

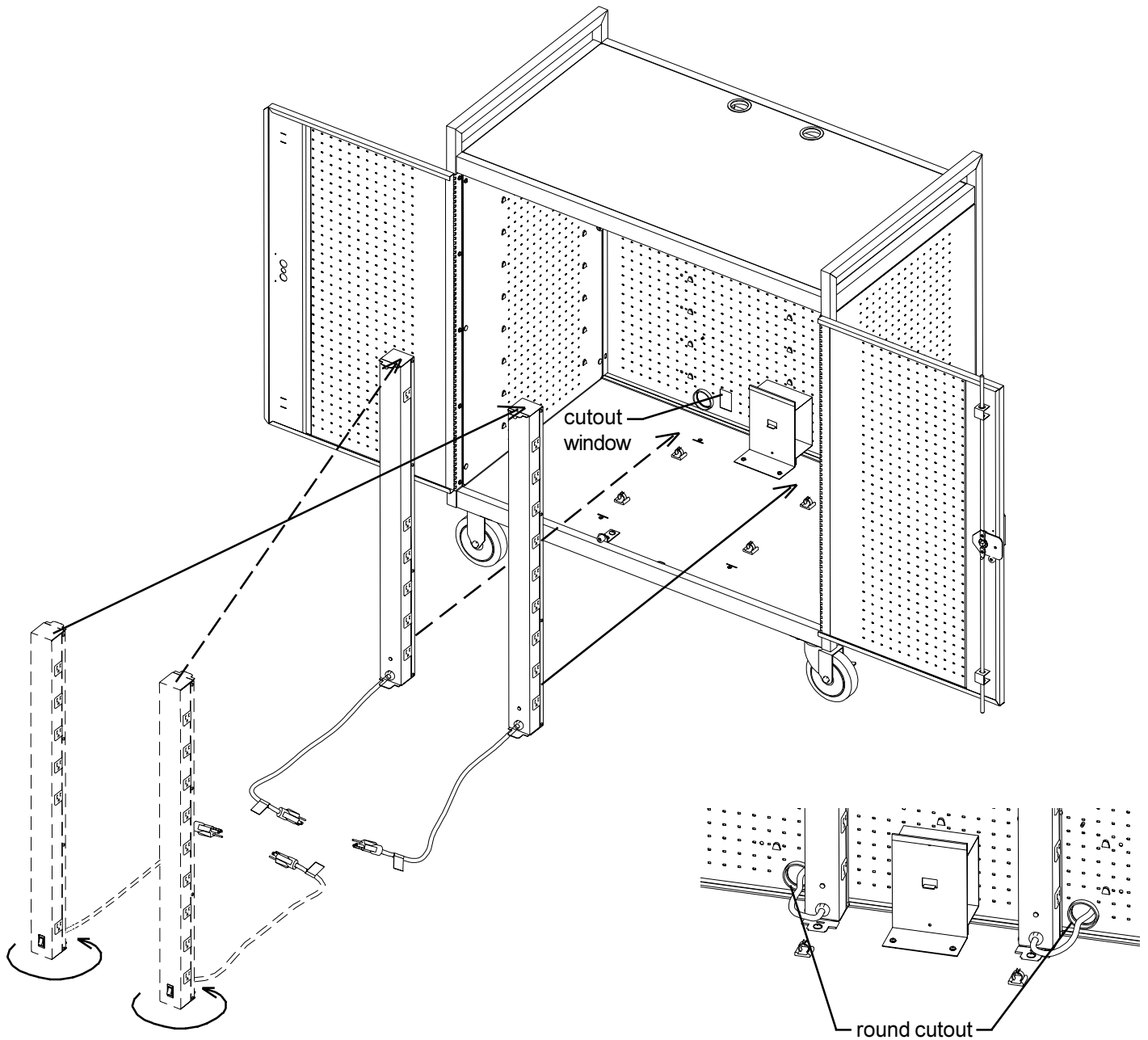

### Step 5

Reinstall the E-Units (set aside from being removed from the front) as follows:

1. Rotate the E-Unit 180 degrees (from original position).
2. Cross over to opposite corner of cart.
3. Tilt in and set bottom in back, in front of rear panel cutout window.
4. Grip the top and tilt to the upright position, underneath top panel bracket.

When repositioned correctly, the E-Unit power switch should be visible from rear panel cutout window. Reinstall the E-Unit bracket assemblies (make sure that the top flange of the E-unit is aligned with the slot in the bracket assembly) and tighten screws securely. Feed the E-Unit power cords (plug end) all the way through the bottom rear grommited round cutouts (next to the bracket assembly) shown in Figure 1. Wind power cords around the cord wrap brackets located on the exterior of the rear panel for storage.

**Figure 1**

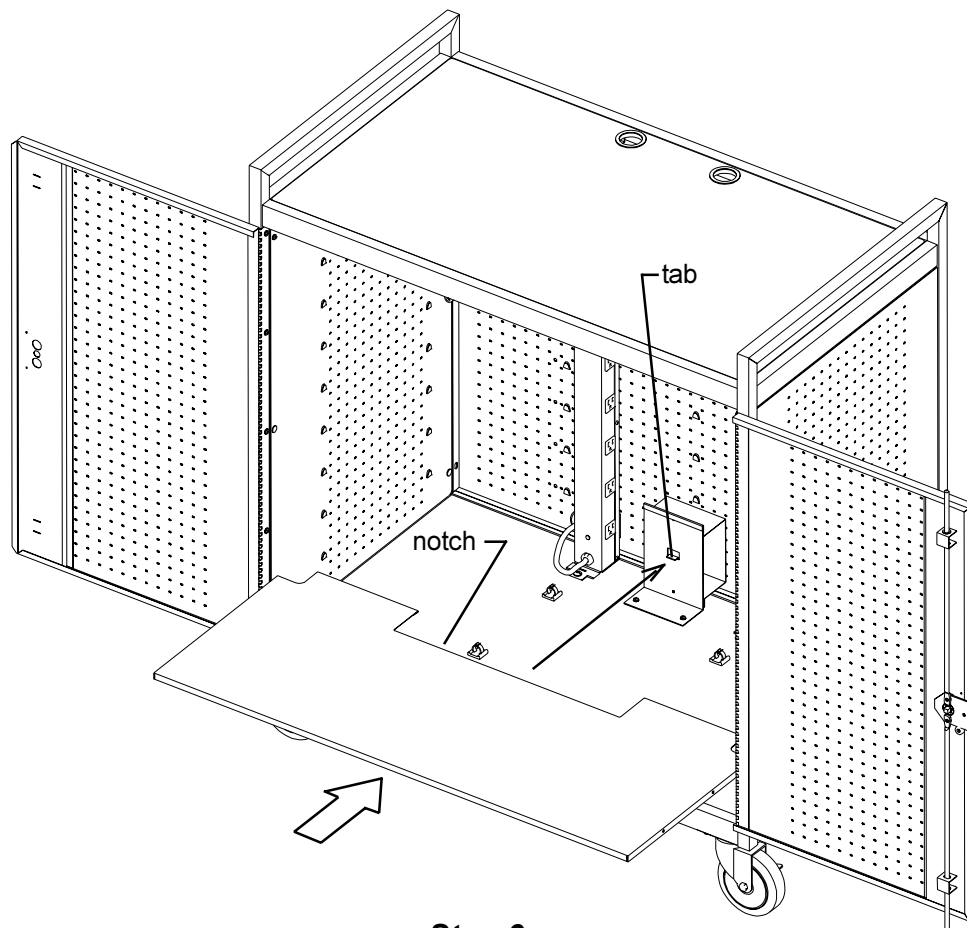

### Step 6

Reinstall the 9 interior shelves as follows:

1. Carefully slide in the shelf with notch, at the **bottom** position (the notch will rest on the bracket tab).  
(Make sure that the shelf flanges are ALL seated into the mounting tabs.)
2. Slide in all remaining shelves into position as the bottom shelf.

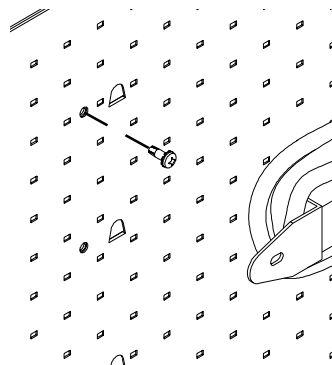
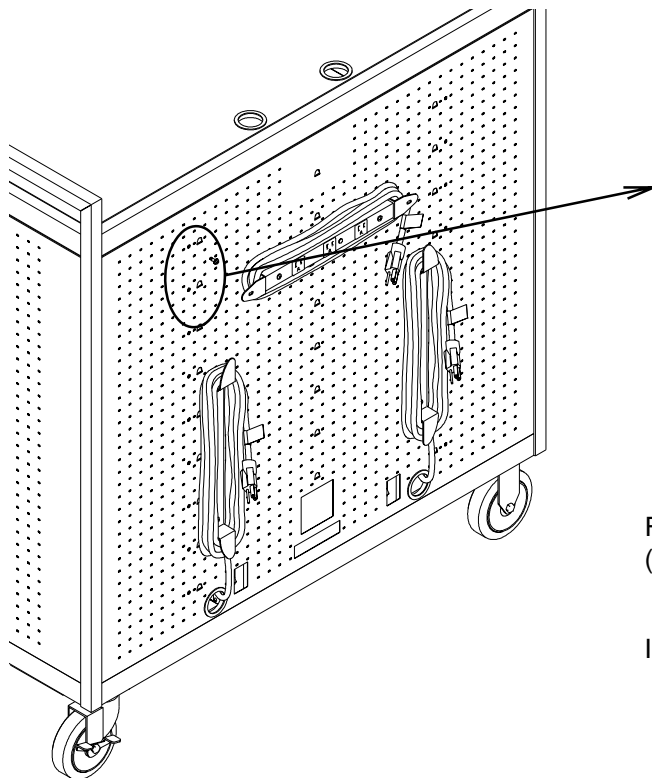

DETAIL 'E'

### Step 7

Reinstall 18 screws to rear panel that will secure the 9 interior shelves (see DETAIL 'E'). **DO NOT OVER TIGHTEN SCREWS.**

Installation is now complete and ready for use.

**NOTE:**

**UNPLUG CART POWER CORDS FROM  
POWER SOURCE BEFORE STARTING**

**E-UNIT REPOSITIONING:  
'REAR TO FRONT'**

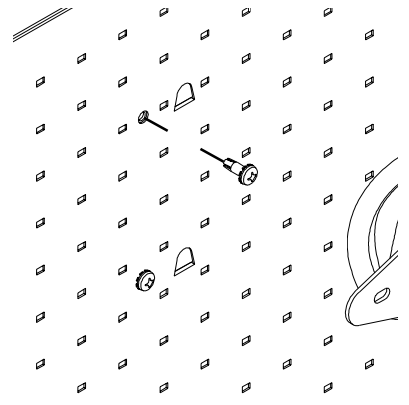
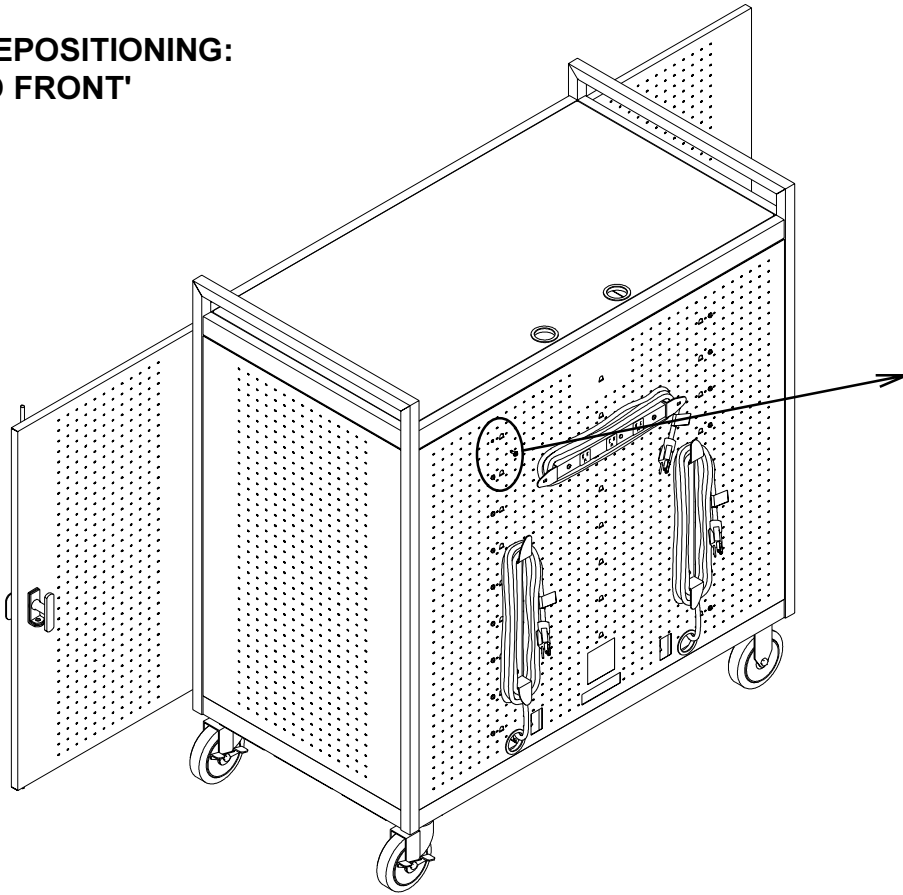

**DETAIL 'A'**

**Step 1**

Remove 18 screws (2 per shelf) from rear panel that secure the 9 interior shelves (see DETAIL 'A').

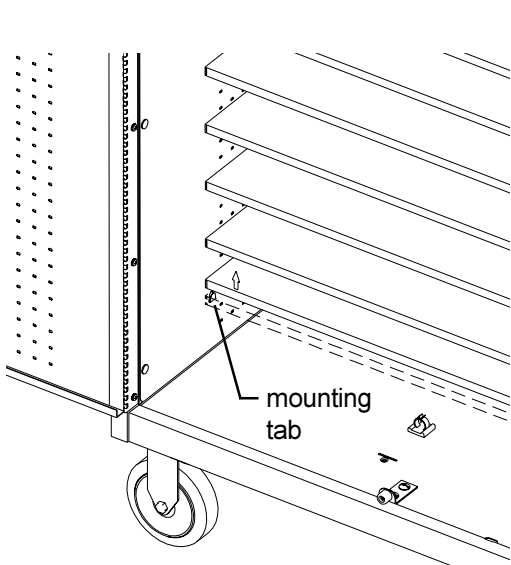

**DETAIL 'B'**

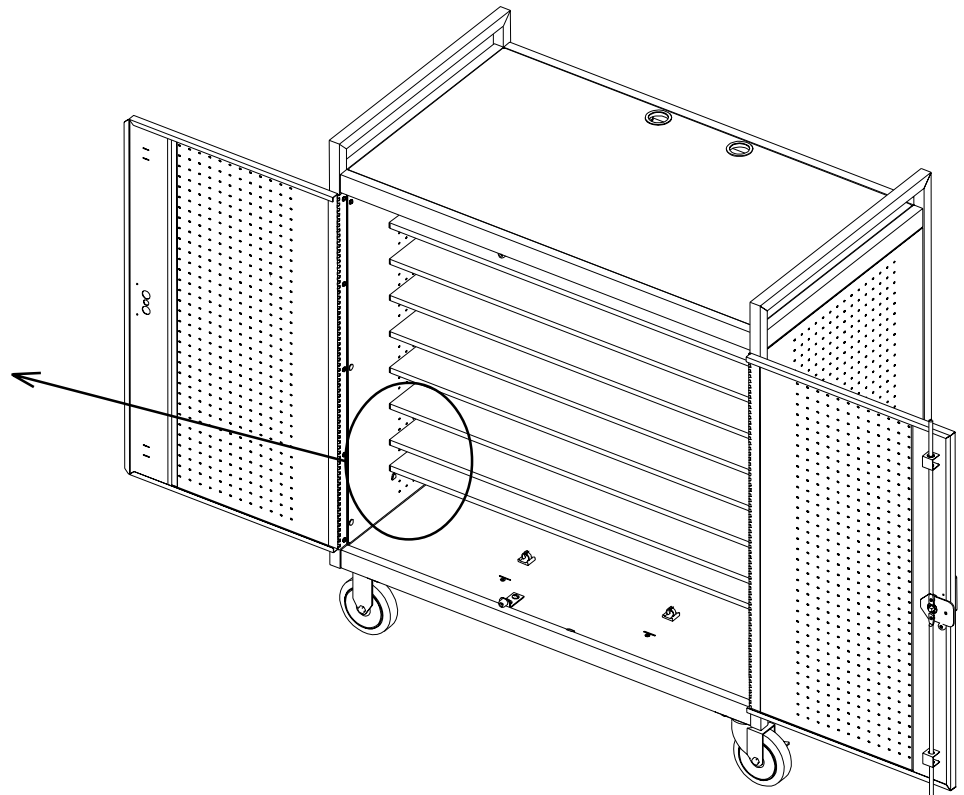

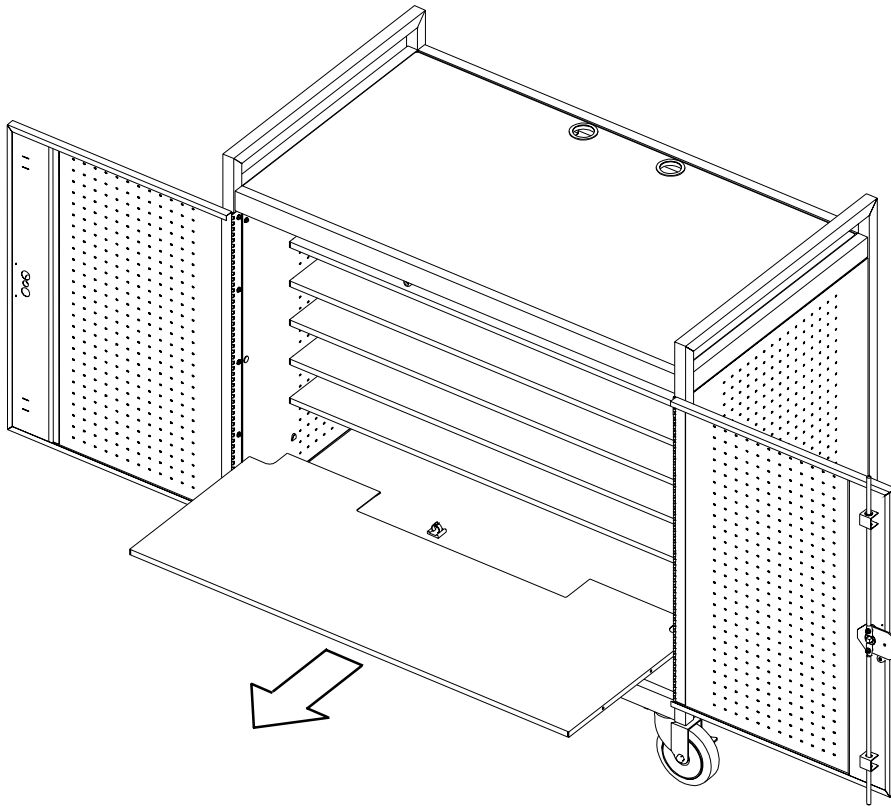

### Step 2

With both doors open, remove each interior shelf by carefully pushing upward (to release shelf from mounting tabs) shown in Detail 'B', then carefully sliding out. Set each shelf aside.

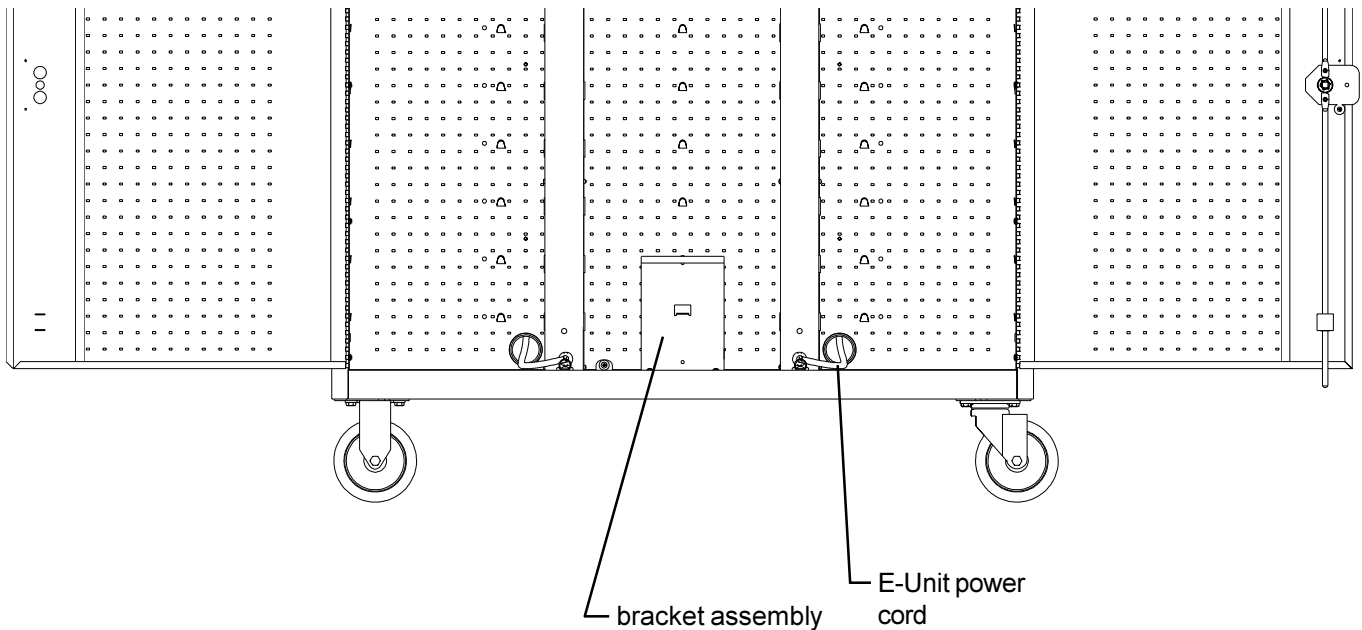

### Front View

Unwind the power cord of the E-Units from the cord wrap brackets (on the rear panel). Loosen the screw holding the E-Unit bracket assembly and remove all 4 bracket assemblies (see DETAILS 'C' and 'D').



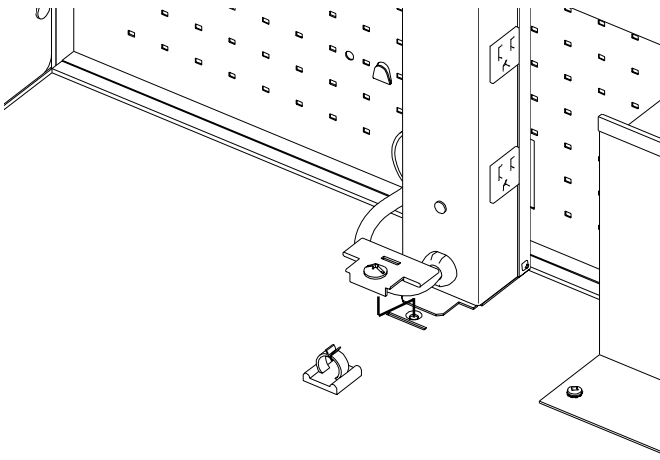

DETAIL 'C'

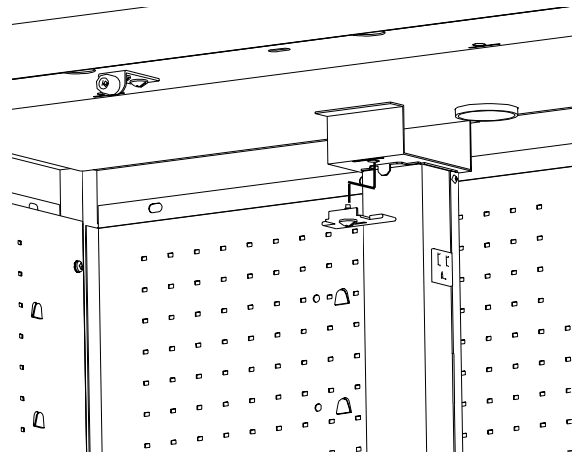

DETAIL 'D'

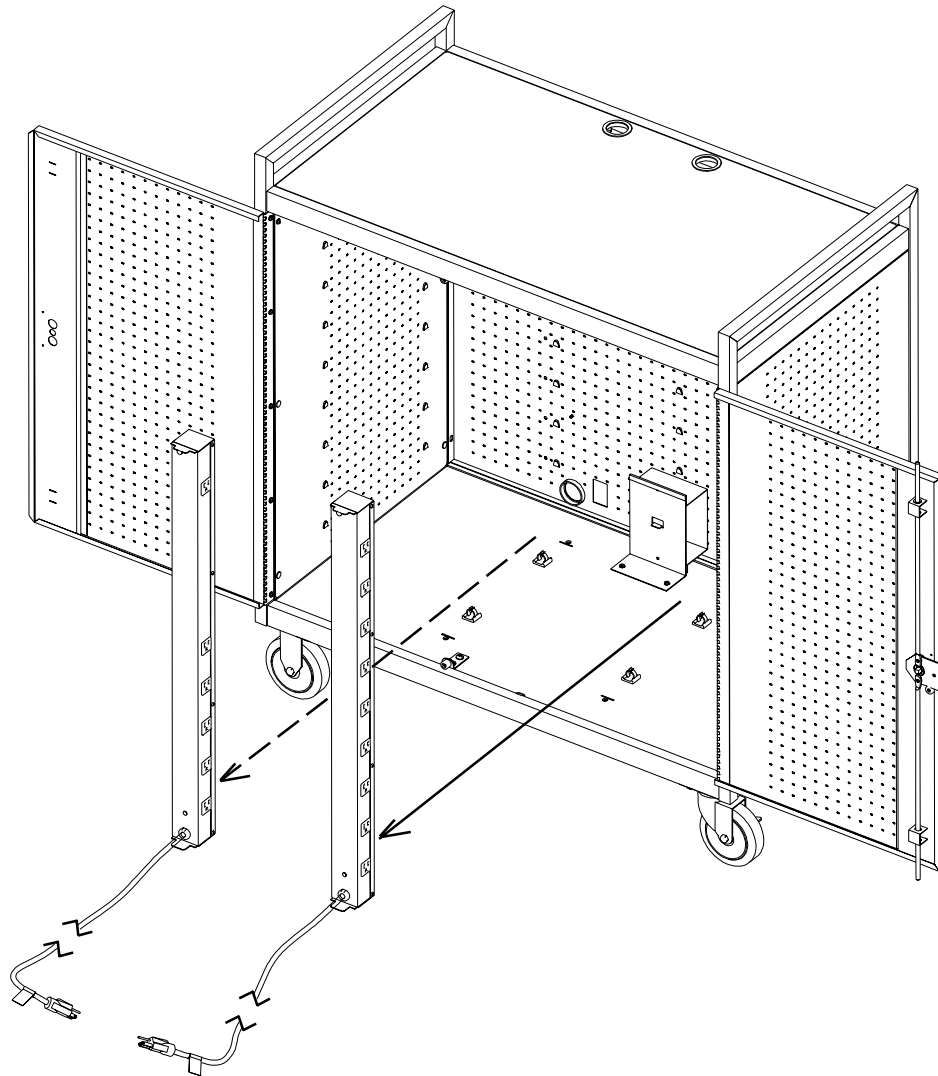

### Step 3

Remove **rear-right** E-Unit by gripping the top and tilt it side ways until it clears the underside of the cart interior shelf bracket and set it aside.

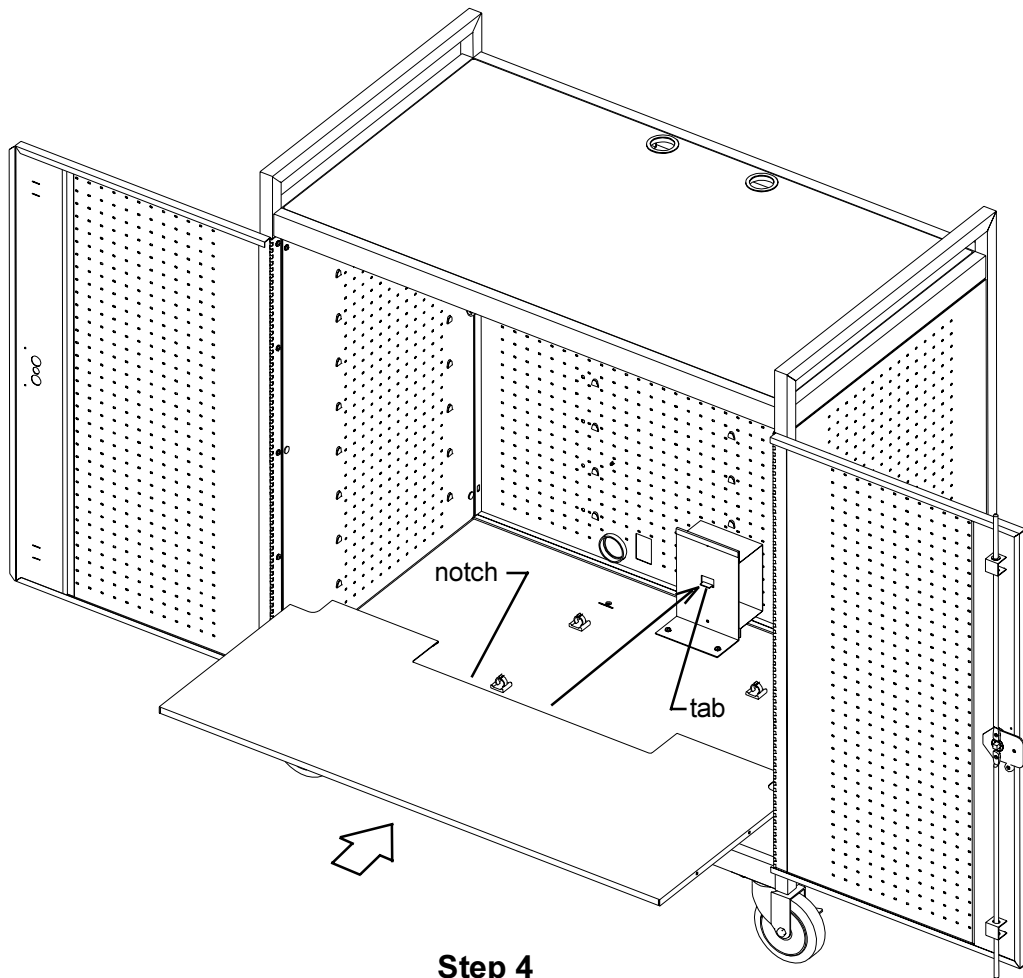

#### Step 4

Reinstall the 9 interior shelves as follows:

1. Carefully slide in the shelf with notch at the **bottom** position (the notch will rest on the bracket tab).  
(Make sure that the shelf flanges are ALL seated into the mounting tabs.)
2. Slide in all remaining shelves into position as the bottom shelf.

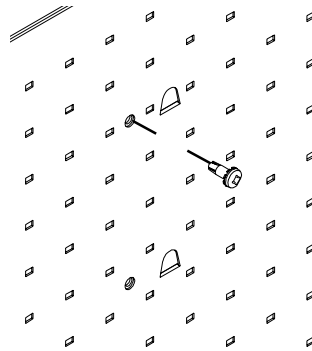
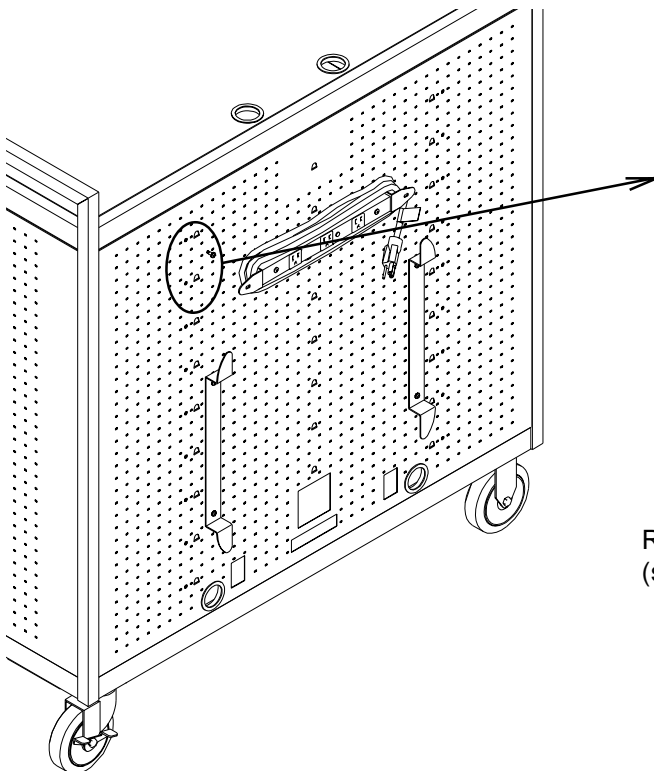

DETAIL 'F'

#### Step 5

Reinstall 18 screws to rear panel that will secure the 9 interior shelves (see DETAIL 'F'). **DO NOT OVER TIGHTEN SCREWS.**

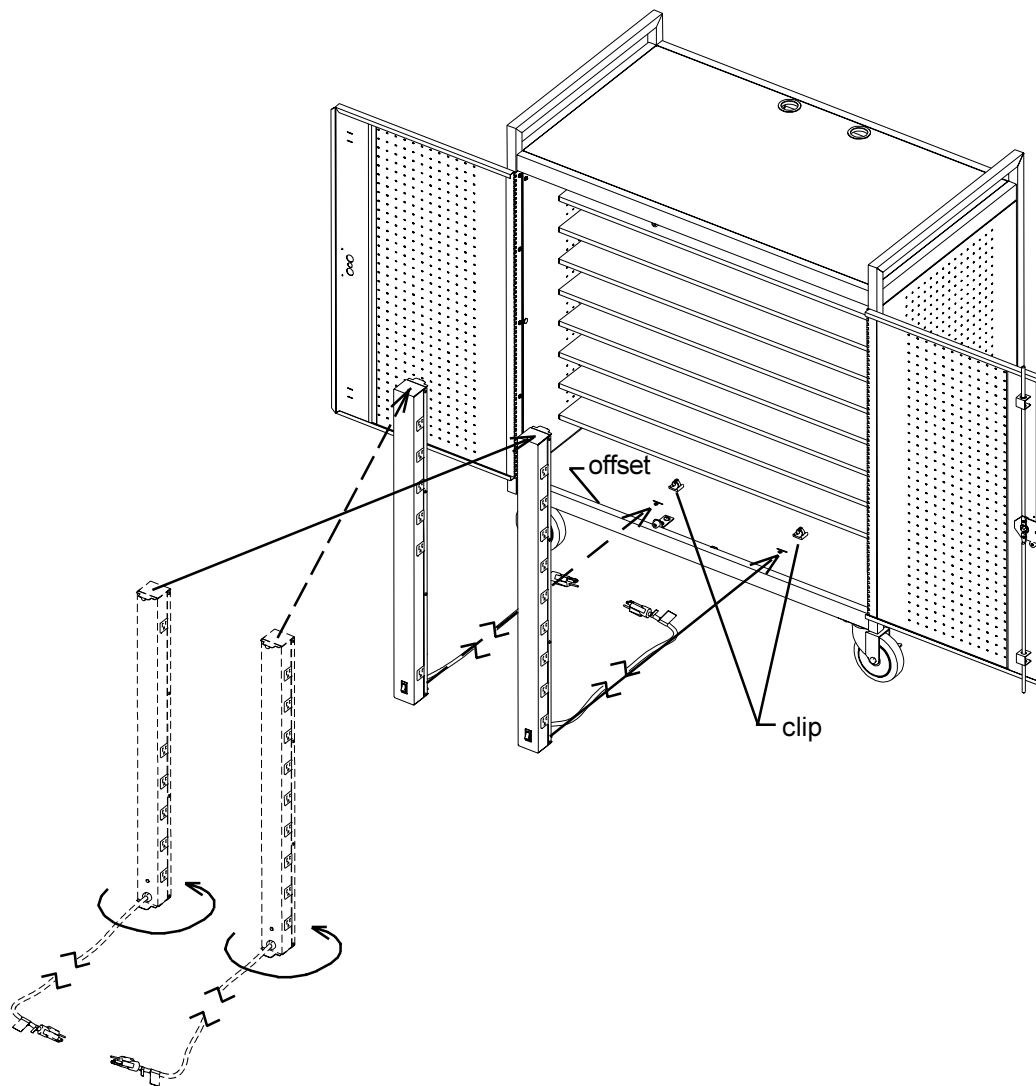

## Step 6

Reinstall the E-Units (set aside from being removed from the rear) as follows:

1. Rotate the E-Unit 180 degrees (from original position).
2. Position to the front of cart.
3. Tilt in and set against offset of bottom panel (of cart).
4. Grip the top and tilt to the upright position.

When repositioned correctly, the E-Unit power switch should face the front.

Reinstall the E-Unit bracket assemblies (make sure that the top flange of the E-unit is aligned with the slot in the bracket assembly) and tighten screws securely.

From underneath the bottom shelf, feed the E-Unit power cords (plug end) all the way through the bottom rear round grommets cutouts (next to bracket assembly).

Press each E-Unit power cord into the two wire clips located (in line, behind E-Unit) on the bottom of cart.

Wind power cords around the cord wrap bracket on the rear panel for storage.

Installation is now complete and ready for use.

**NOTE:**

**UNPLUG CART POWER CORDS FROM  
POWER SOURCE BEFORE STARTING**

**E-UNIT REPLACEMENT:  
'REAR LOCATION'**

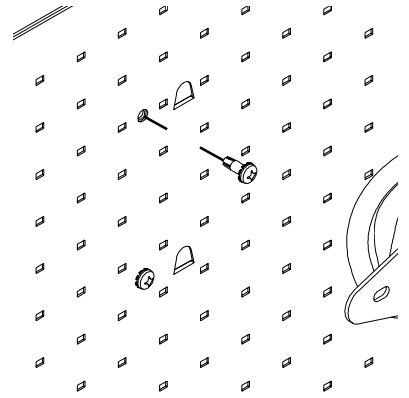
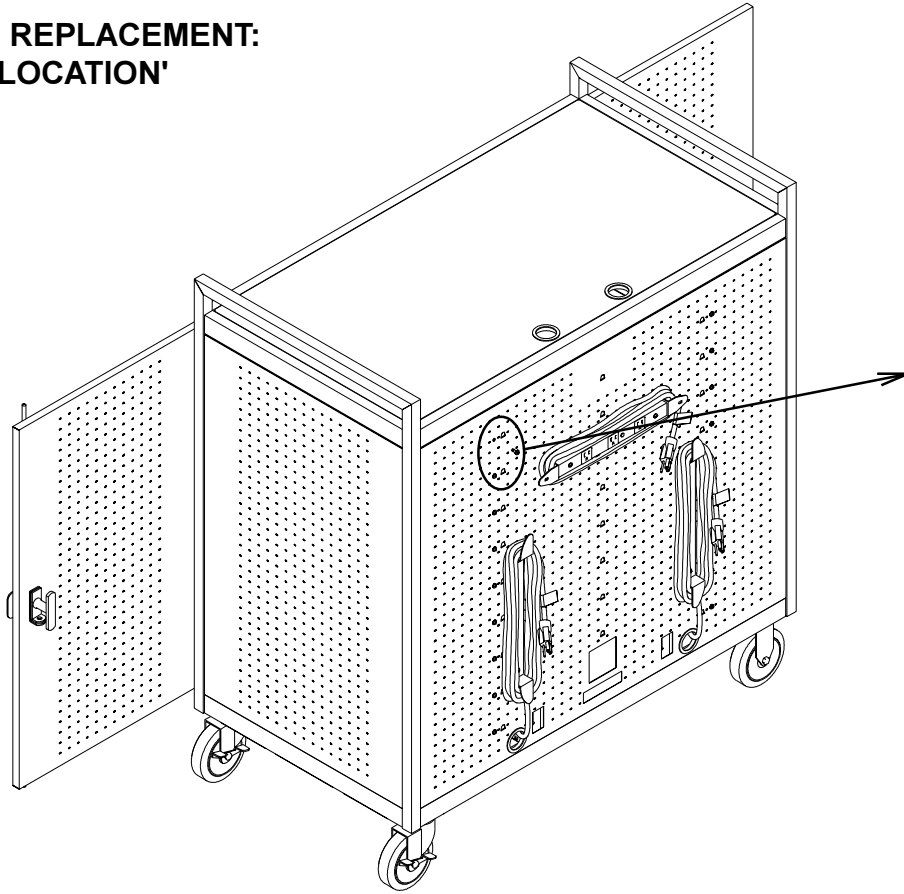

**DETAIL 'A'**

**Step 1**

Remove 18 screws (2 per shelf) from rear panel that secure the 9 interior shelves (see DETAIL 'A').

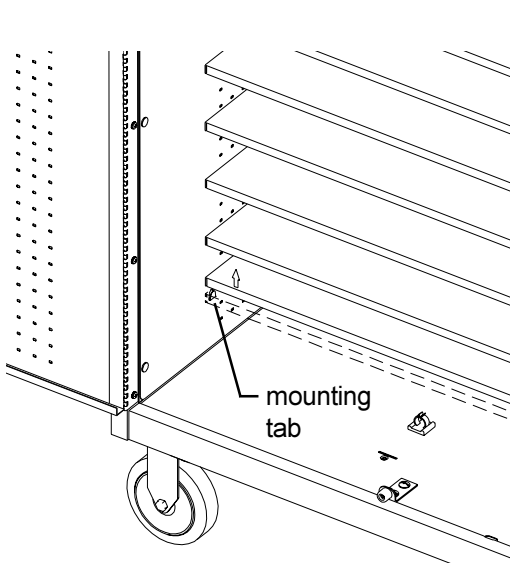

**DETAIL 'B'**

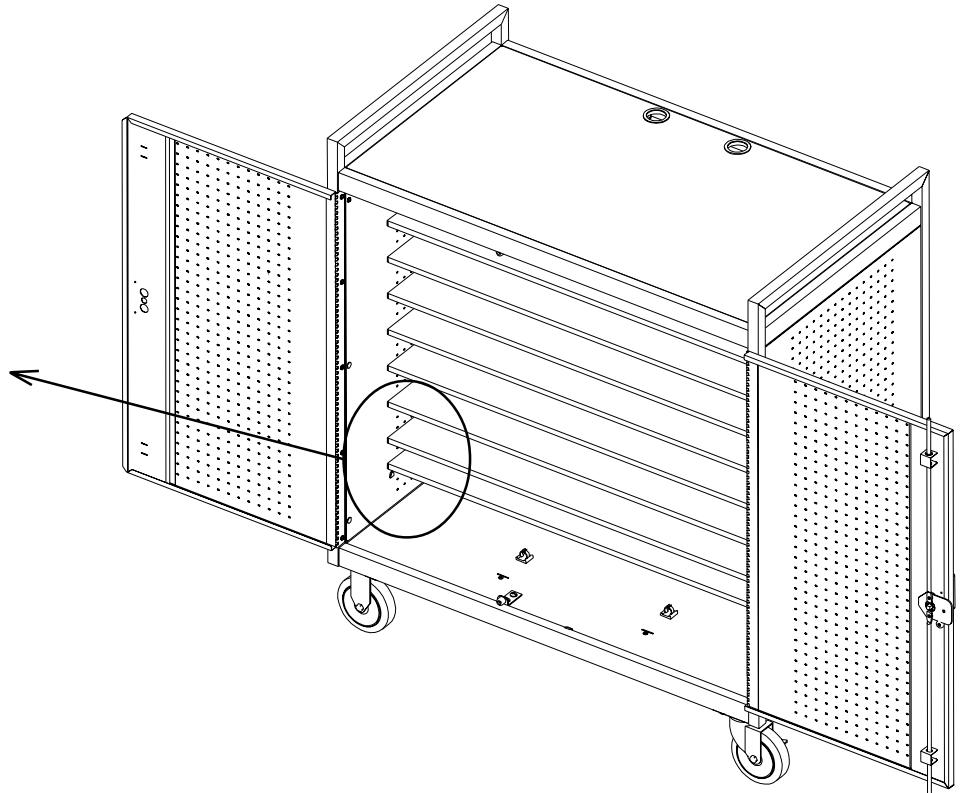

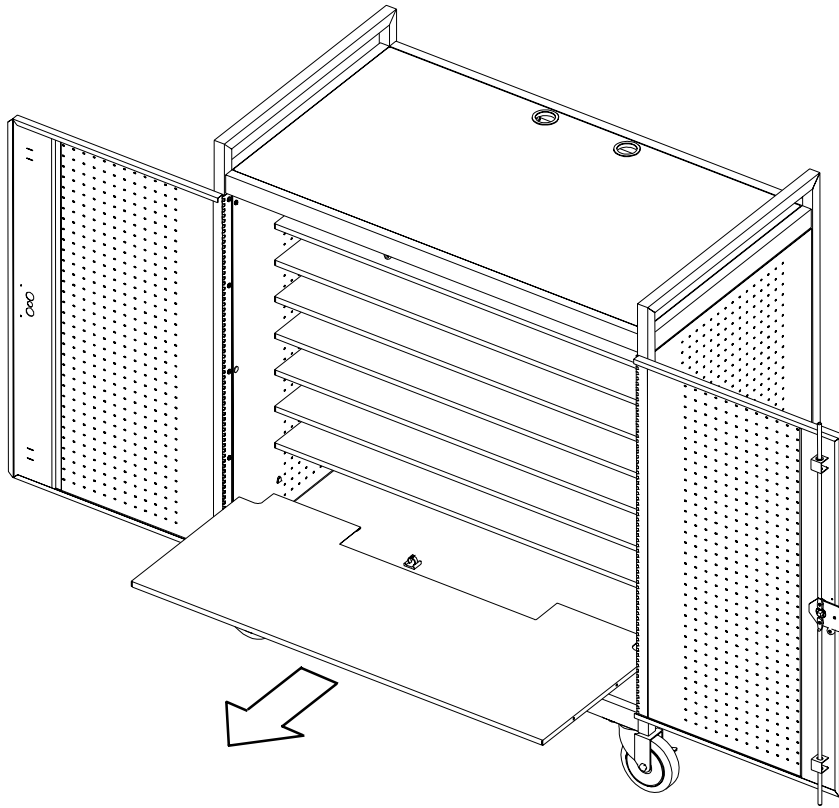

### Step 2

With both doors open, remove each interior shelf by carefully pushing upward (to release shelf from mounting tabs) shown in Detail 'B', then carefully sliding out. Set each shelf aside.

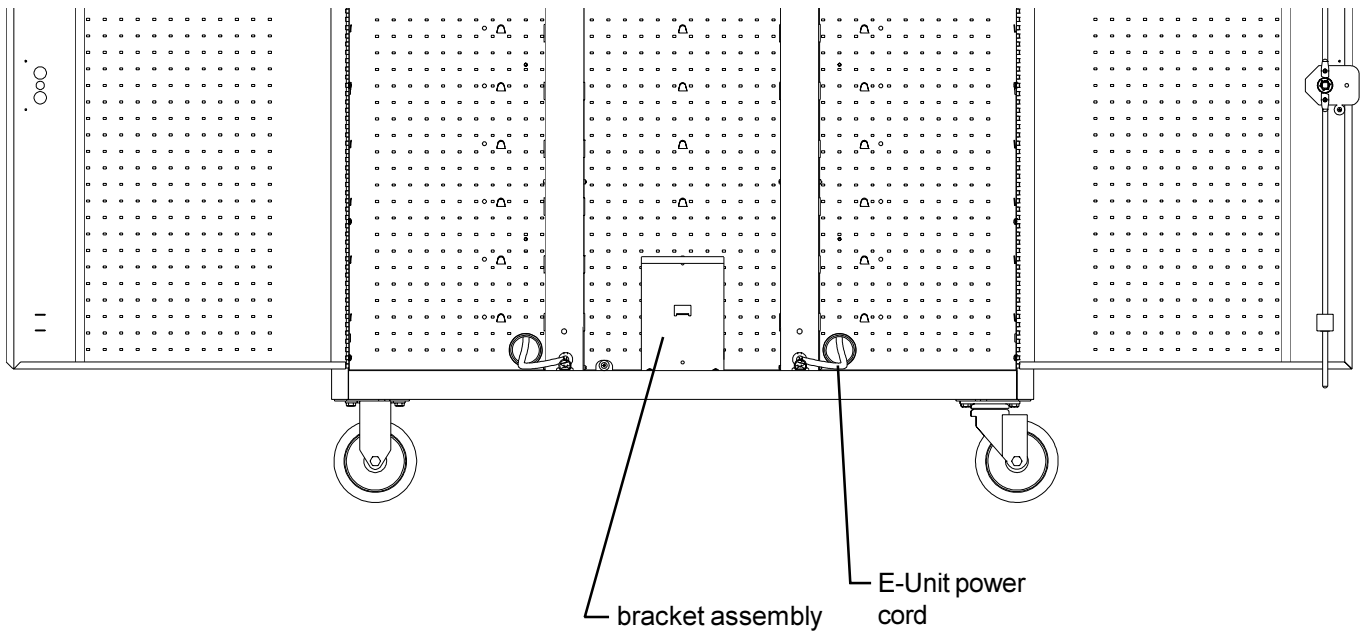

### Front View

Unwind the power cord of the E-Units from the cord wrap brackets (on the rer panel). Loosen the screw holding the E-Unit bracket assembly and remove all 4 bracket assemblies (see DETAILS 'C' and 'D').

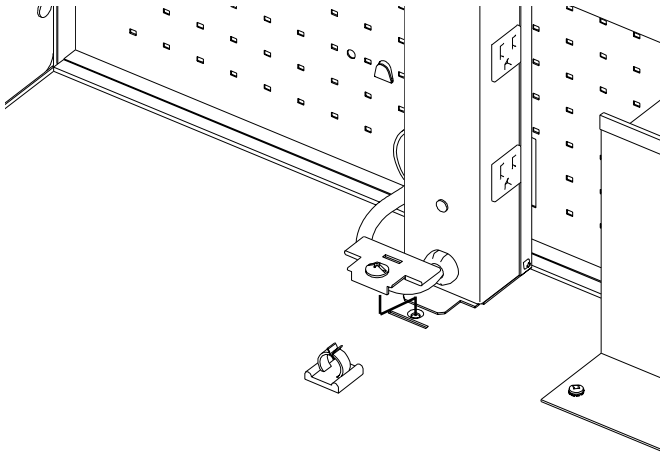

**DETAIL 'C'**

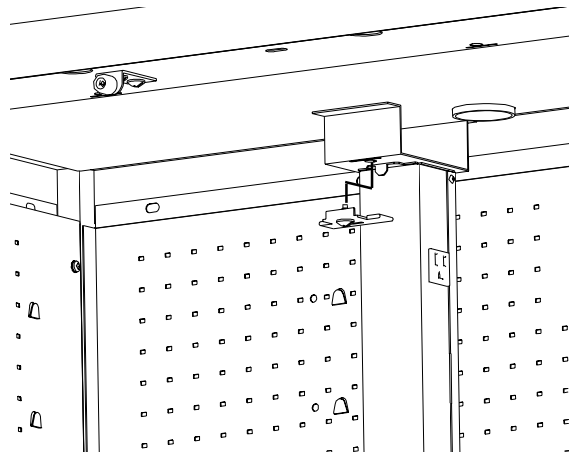

**DETAIL 'D'**

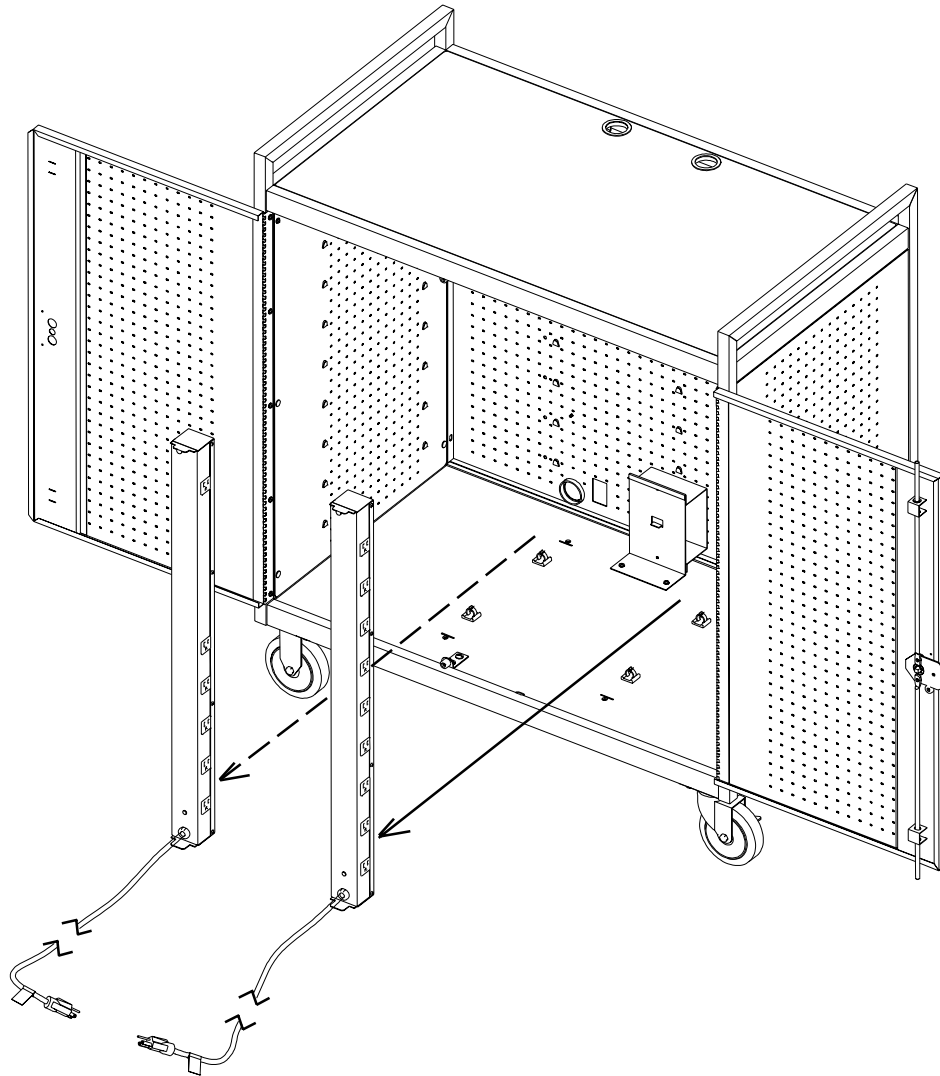

**Step 3**

Remove E-Unit(s) by gripping the top and tilt it side ways until it clears the underside of the cart interior shelf bracket and set it aside.

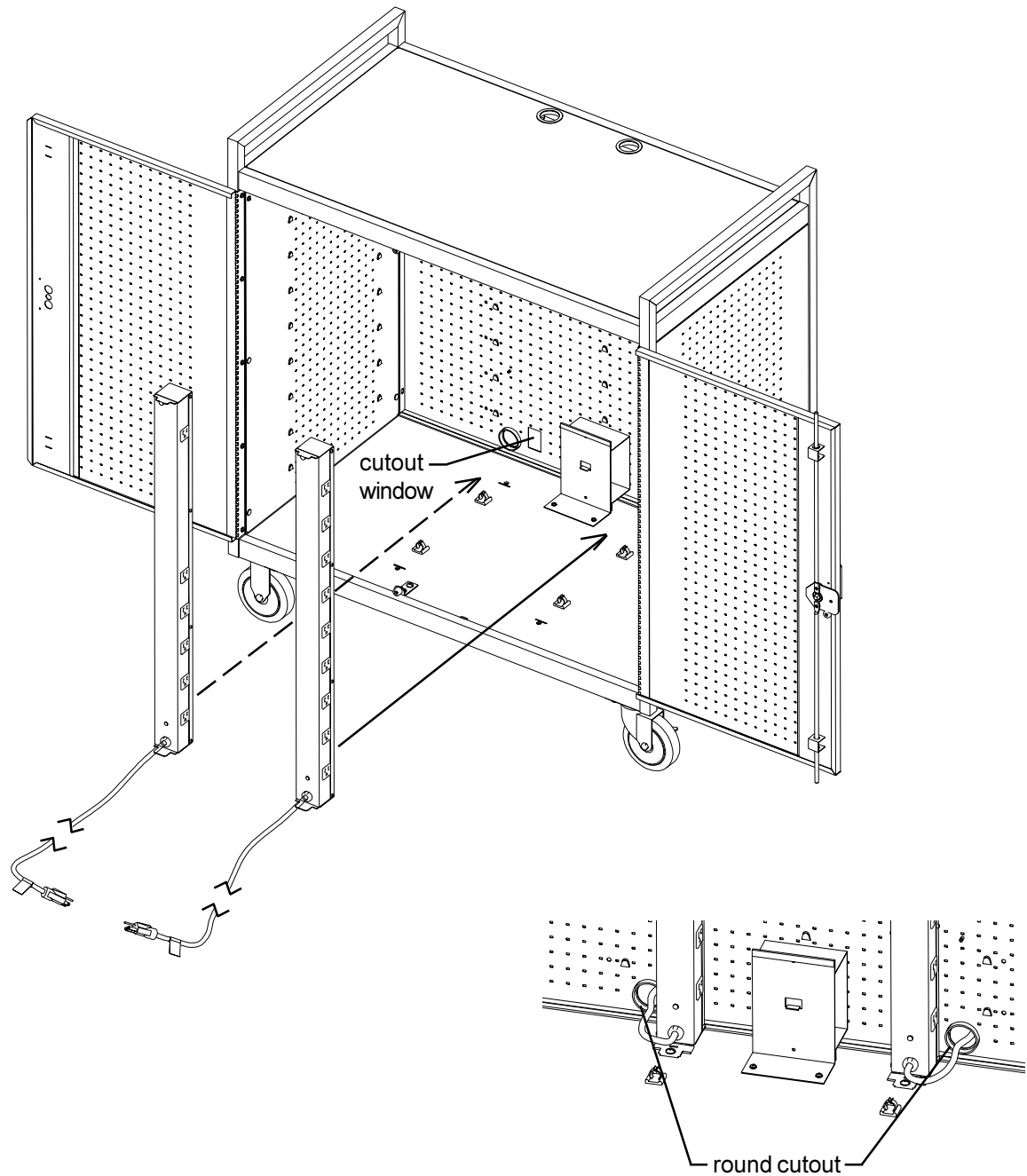

**Figure 1**

#### **Step 4**

Carefully install replacement E-Unit(s) into position by placing bottom in first and tilting in sideways to the top. When repositioned correctly, the E-Unit(s) power switch should be visible from rear panel cutout window. Reinstall the E-Unit bracket assemblies (make sure that the top flange of the E-unit is aligned with the slot in the bracket assembly) and tighten screws securely. Feed the E-Unit power cord(s) [plug end] all the way through the bottom rear grommeted round cutout(s) [next to the bracket assembly] shown in Figure 1. Wind power cord(s) around the cord wrap bracket(s) located on the exterior of the rear panel for storage.

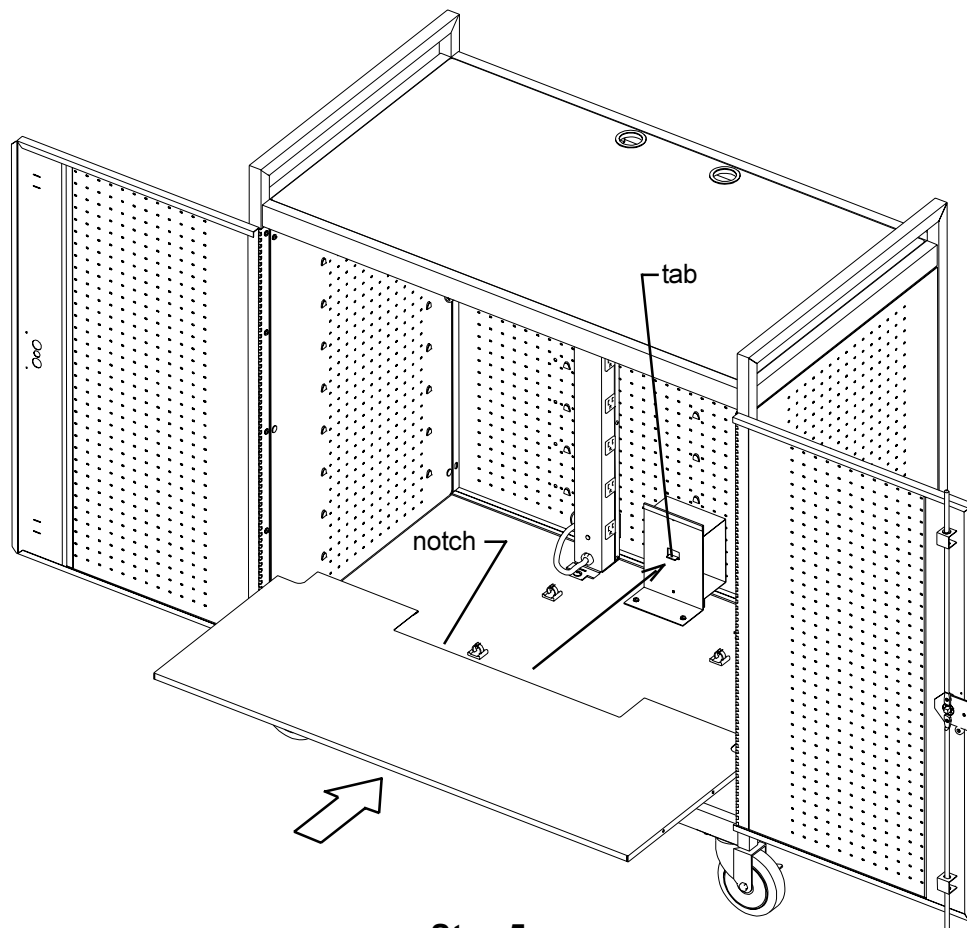

### Step 5

Reinstall the 9 interior shelves as follows:

1. Carefully slide in the shelf with notch, at the **bottom** position (the notch will rest on the bracket tab).  
(Make sure that the shelf flanges are ALL seated into the mounting tabs.)
2. Slide in all remaining shelves into position as the bottom shelf.

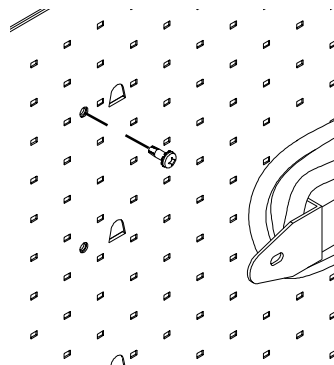
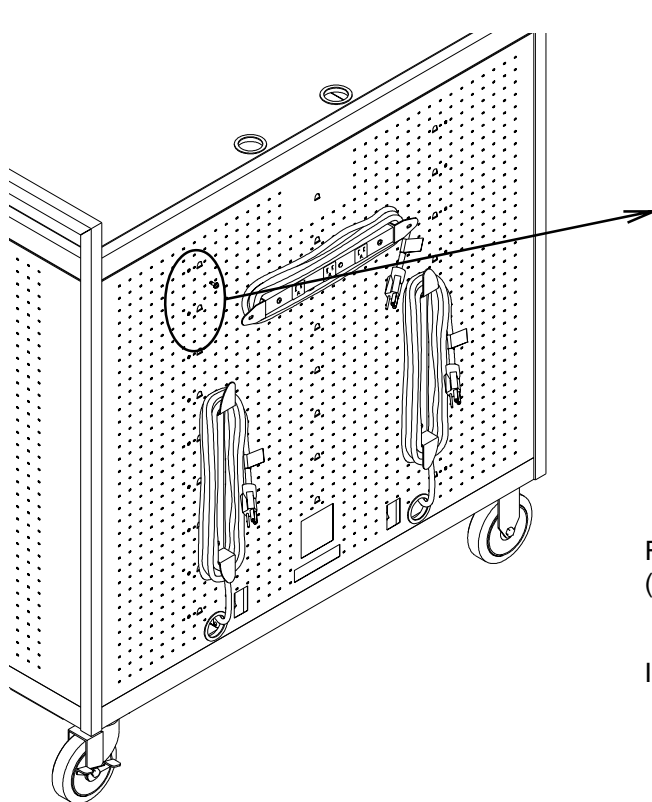

DETAIL 'E'

### Step 6

Reinstall 18 screws to rear panel that will secure the 9 interior shelves (see DETAIL 'E'). **DO NOT OVER TIGHTEN SCREWS.**

Installation is now complete and ready for use.



**NOTE:**

**UNPLUG CART POWER CORDS FROM  
POWER SOURCE BEFORE STARTING**

**E-UNIT REPLACEMENT:  
'FRONT LOCATION'**

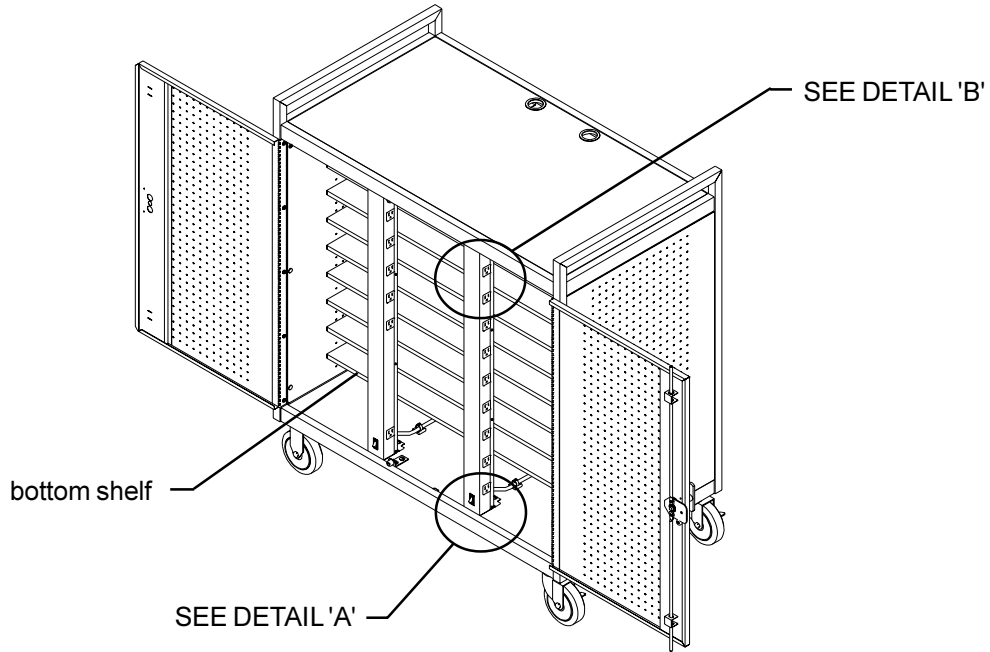

**Step 1**

Open both front doors of cart to access E-Unit(s). Unwind any length of E-Unit power cord remaining on the exterior rear panel cord wrap bracket(s). From underneath the bottom shelf (see Front View), carefully unclip the power cord(s) from the 2 clips located at the bottom panel of the cart. Loosen the screw holding the E-Unit bracket assembly and remove (2) bracket assemblies of the E-Unit(s) to be replaced (see DETAILS 'A' and 'B').

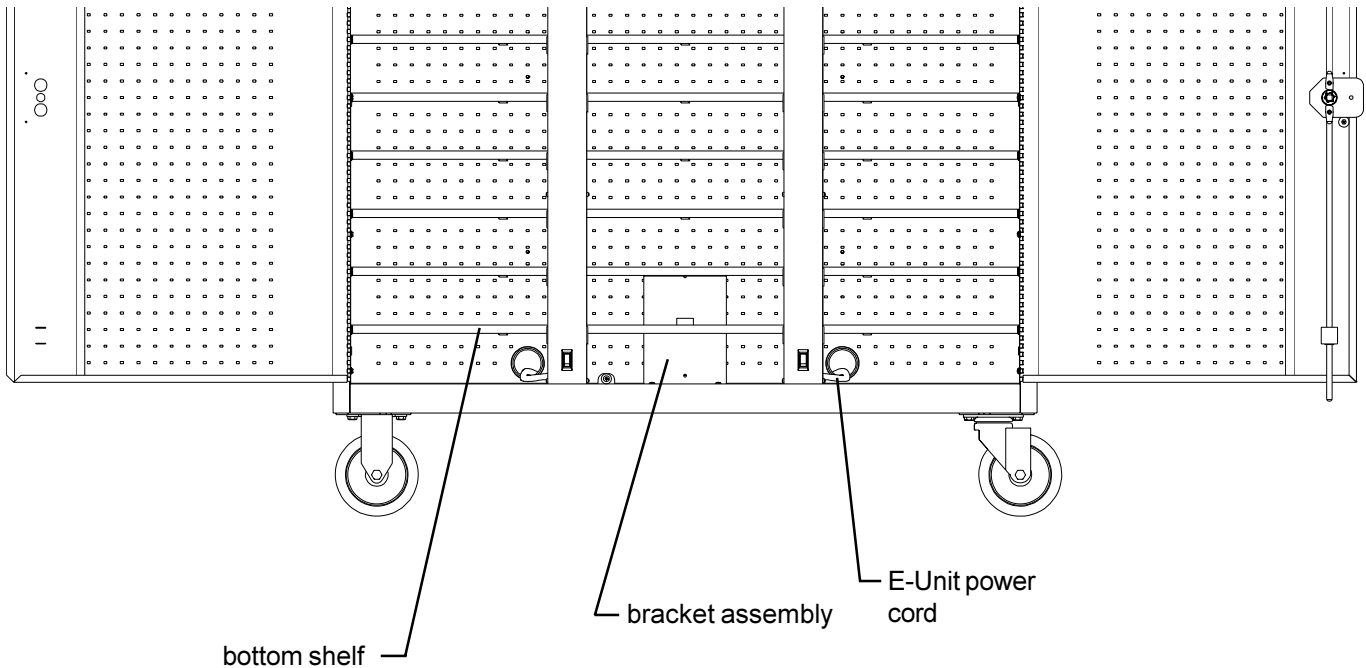

**Front View**

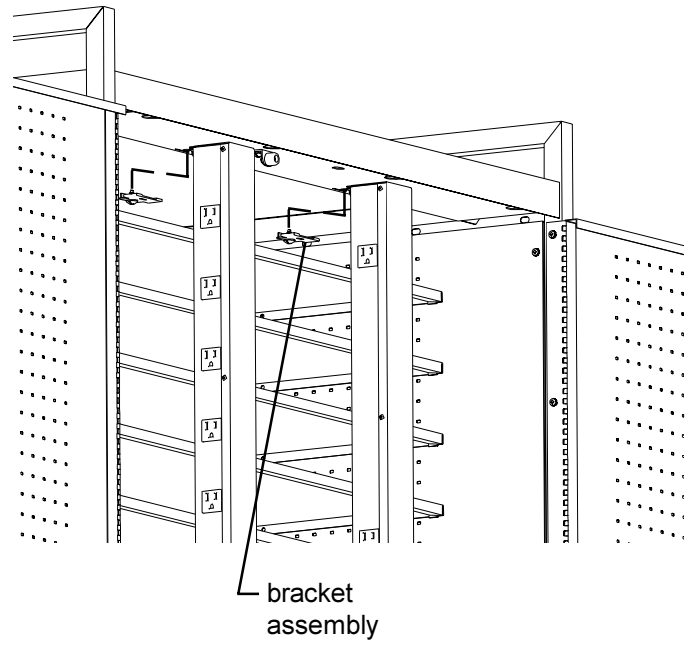
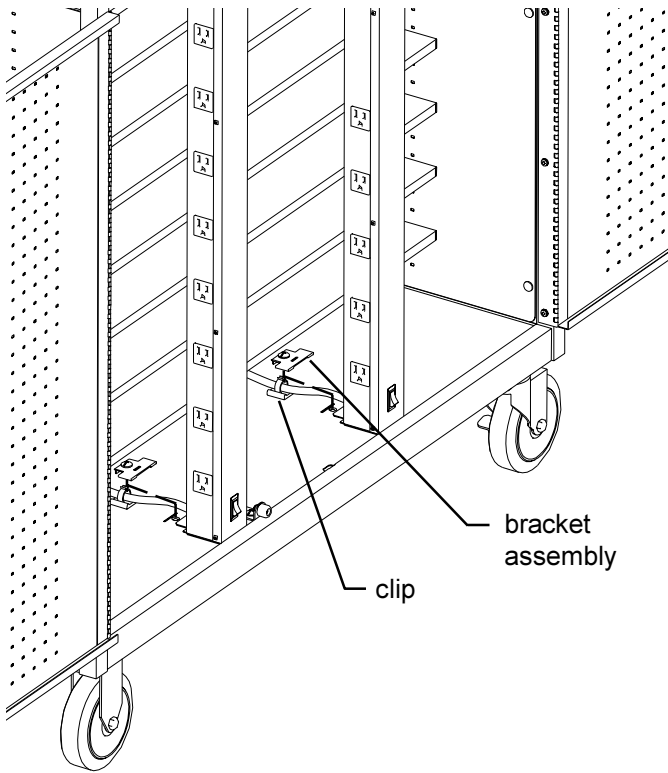

**DETAIL 'B'**

**DETAIL 'A'**

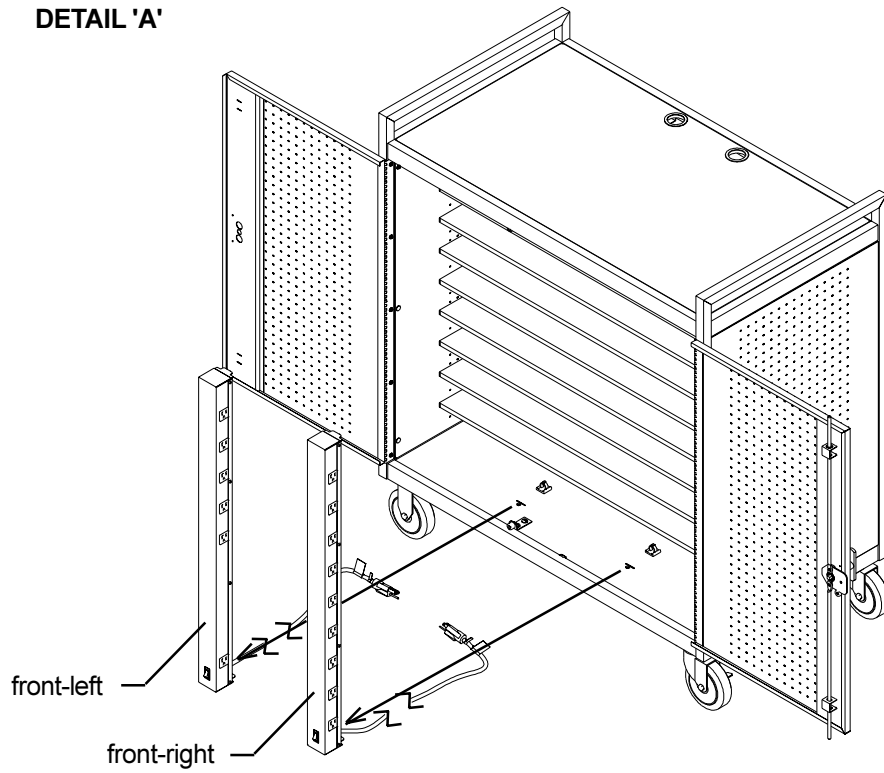

**Step 2**

Remove E-Unit(s) by gripping the top and tilt it side ways until it clears the underside of the cart interior shelf channel and set it aside.

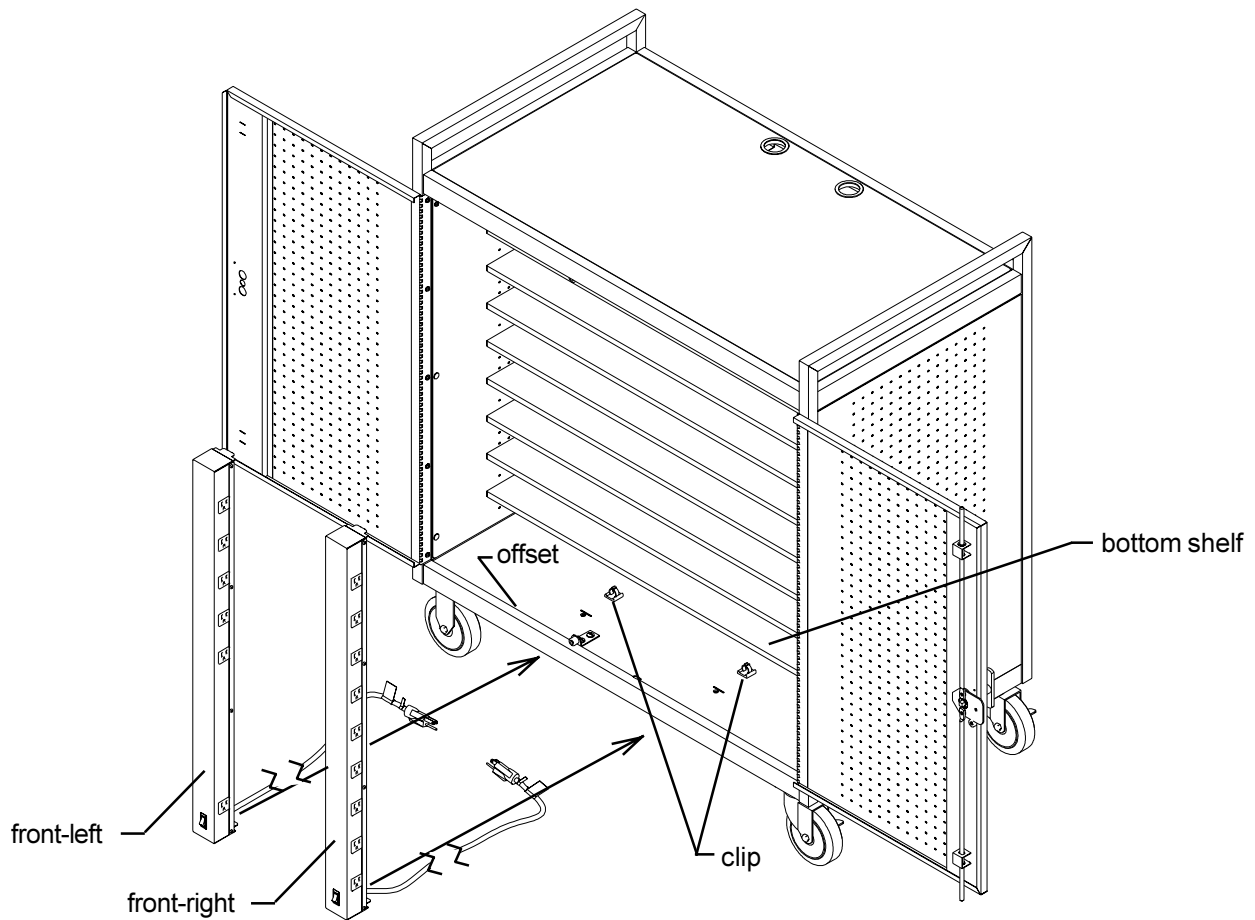

### Step 3

Carefully install replacement E-Unit(s) into position by placing bottom in first against the offset and tilting it in sideways to the top.

When repositioned correctly, the E-Unit(s) power switch should face the front.

Reinstall the E-Unit bracket assemblies (make sure that the top flange of the E-unit is aligned with the slot in the bracket assembly) and tighten screws securely.

From underneath the bottom shelf, feed the E-Unit power cord(s) [plug end] all the way through the bottom rear round grommated cutout(s) [next to bracket assembly].

Press each E-Unit power cord into the two wire clip(s) located [in line, behind E-Unit] on the bottom of cart.

Wind power cord(s) around the cord wrap bracket on the exterior rear panel for storage.

Installation is now complete and ready for use.

**NOTE:**  
**UNPLUG CART POWER CORDS FROM**  
**POWER SOURCE BEFORE STARTING**

**TIMER REPLACEMENT:**  
**'E-UNIT AT REAR LOCATION'**

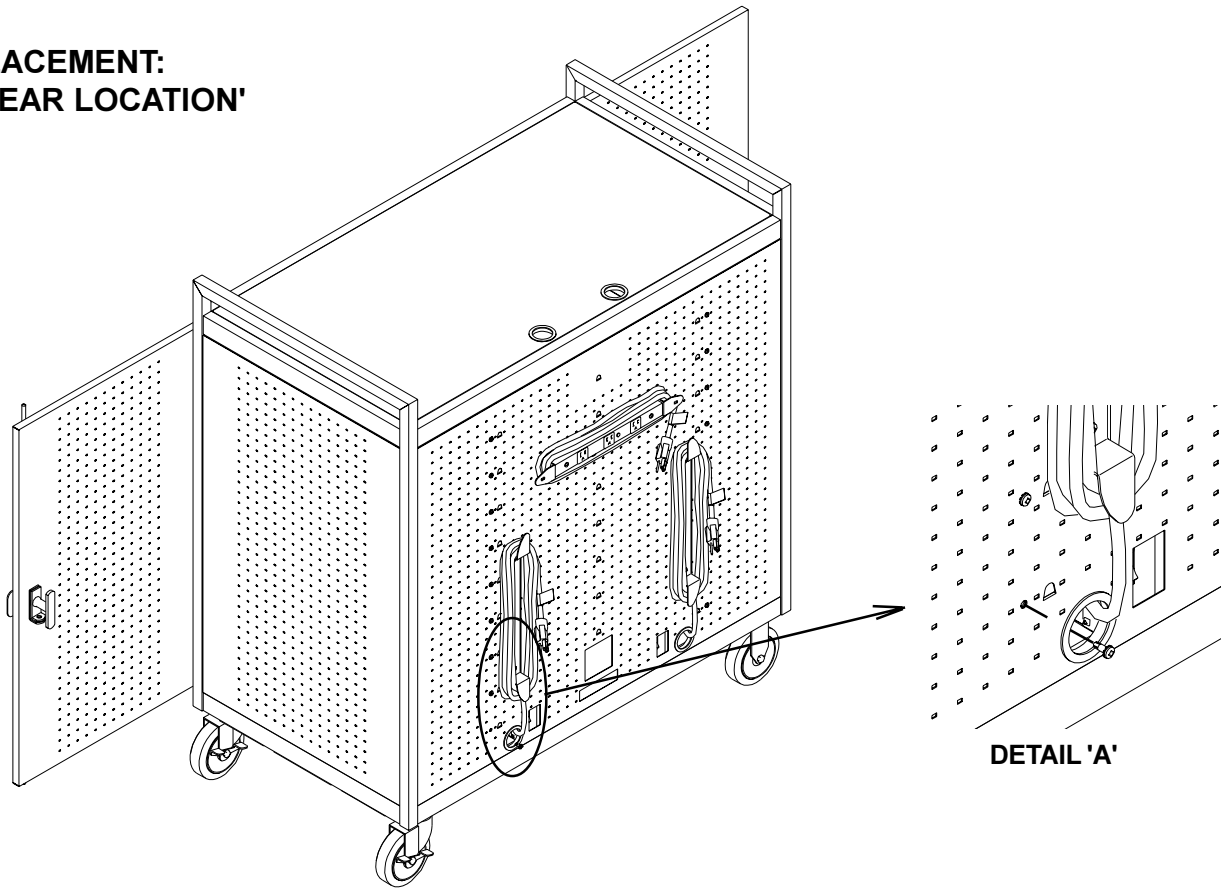

**Step 1**

Remove 6 screws (2 per shelf) from rear panel that secure the 3 **bottom** interior shelves (see DETAIL 'A').

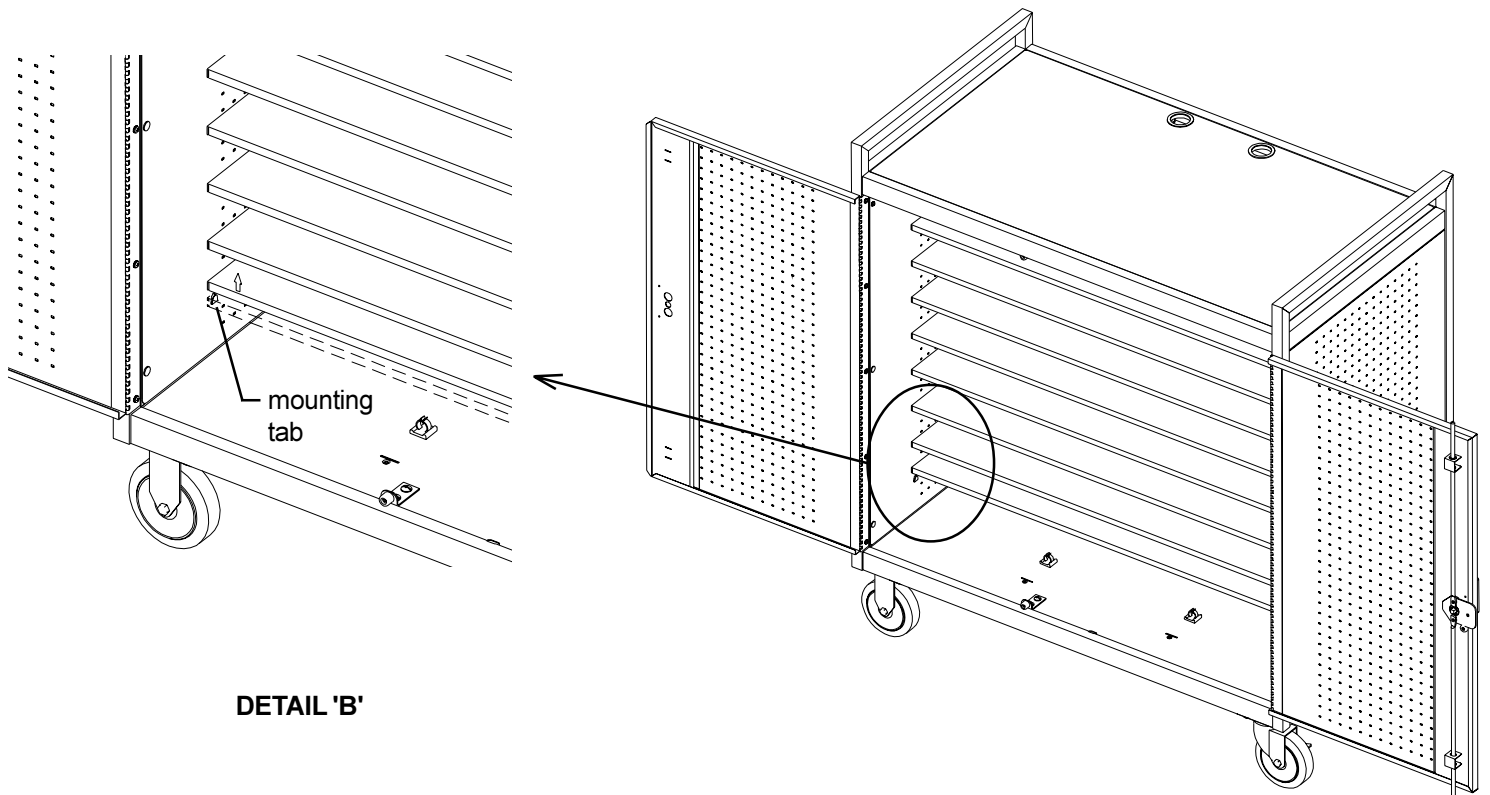

**DETAIL 'B'**

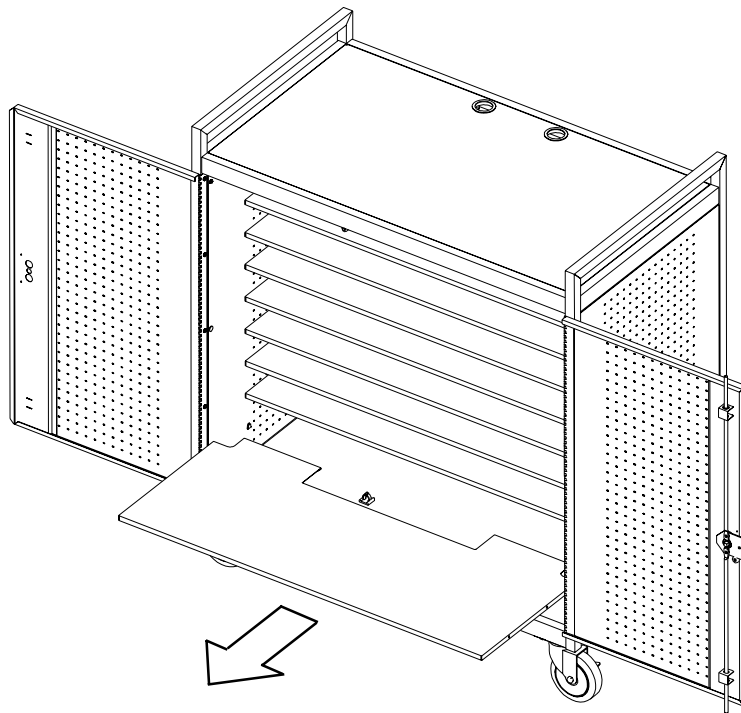

### Step 2

With both doors open, remove the 3 bottom interior shelves by carefully pushing upward (to release shelf from mounting tabs) shown in Detail 'B', then carefully sliding out. Set each shelf aside.

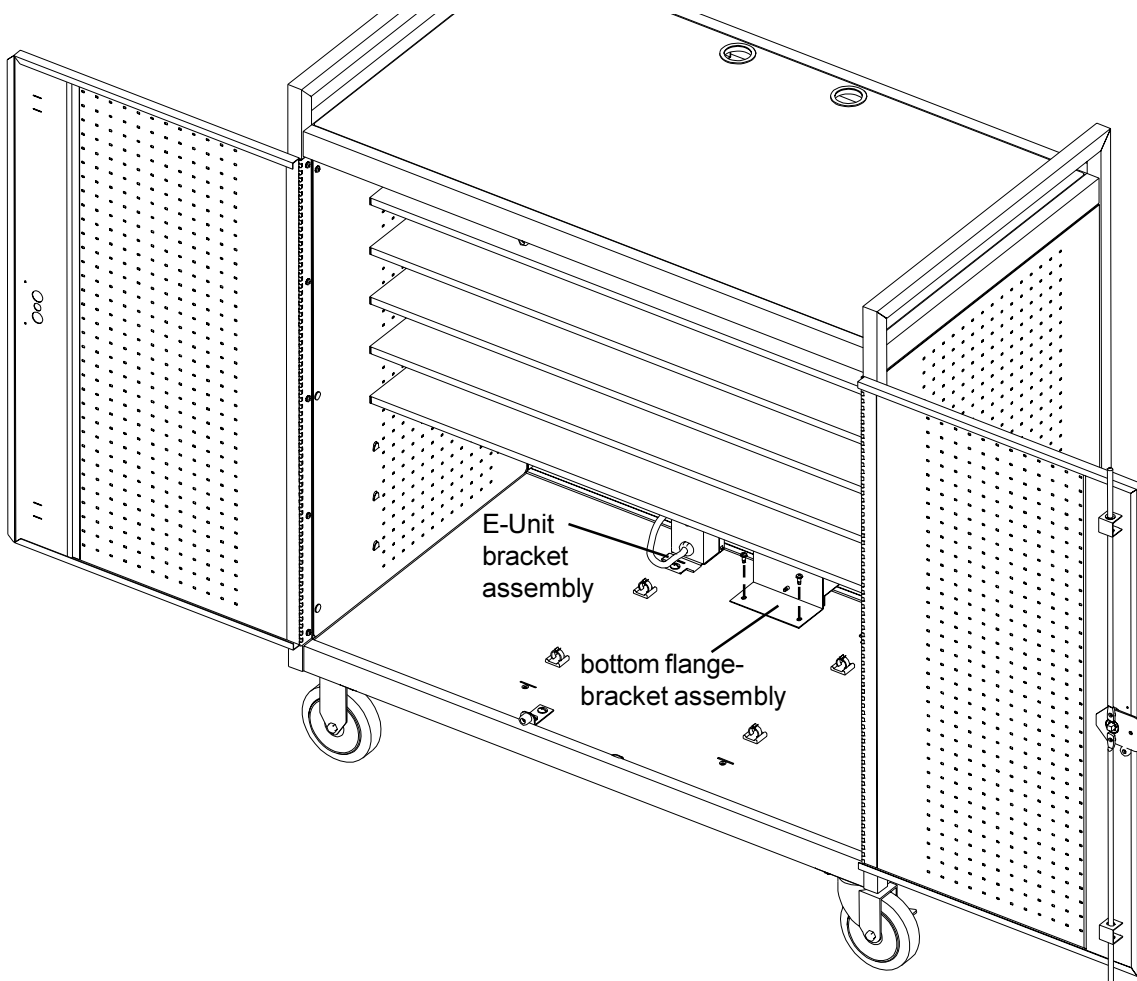

### Step 3

Remove 2 screws from bottom flange (securing bracket to bottom of cart) and remove bracket assembly. The E-Unit bracket assembly shown above, will need to be removed (with a philips screwdriver) to allow the E-Unit to swing back. This will allow the timer cord plug to pass between the E-Unit and rear panel.

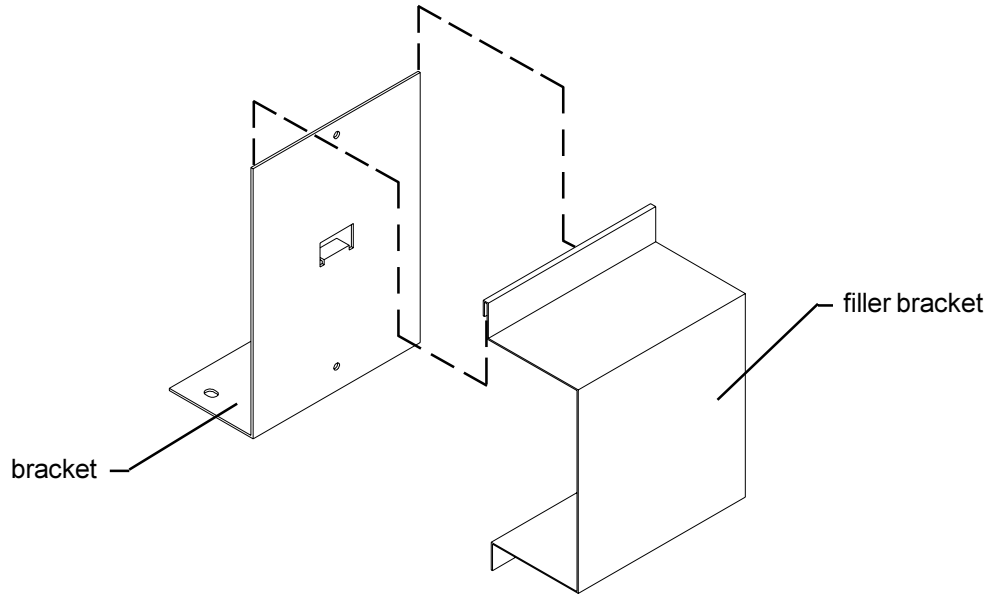

#### Step 4

Remove filler bracket from bracket by pulling upward.  
Discard filler bracket.

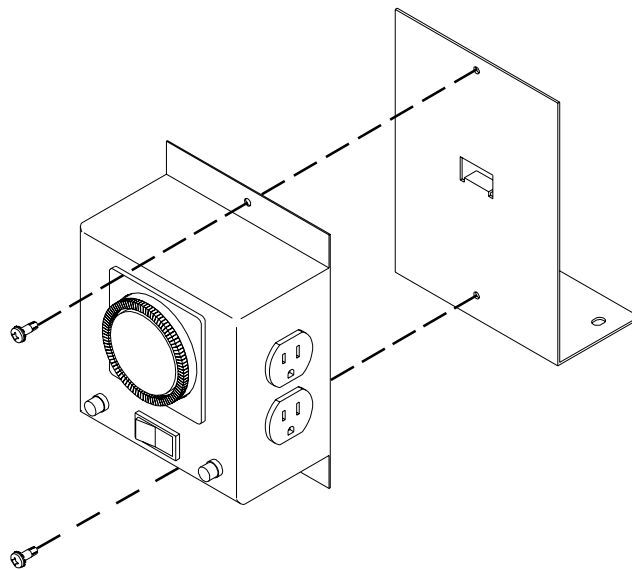

#### Step 5

Install timer with 2 screws. Adjust timer dial to current time.

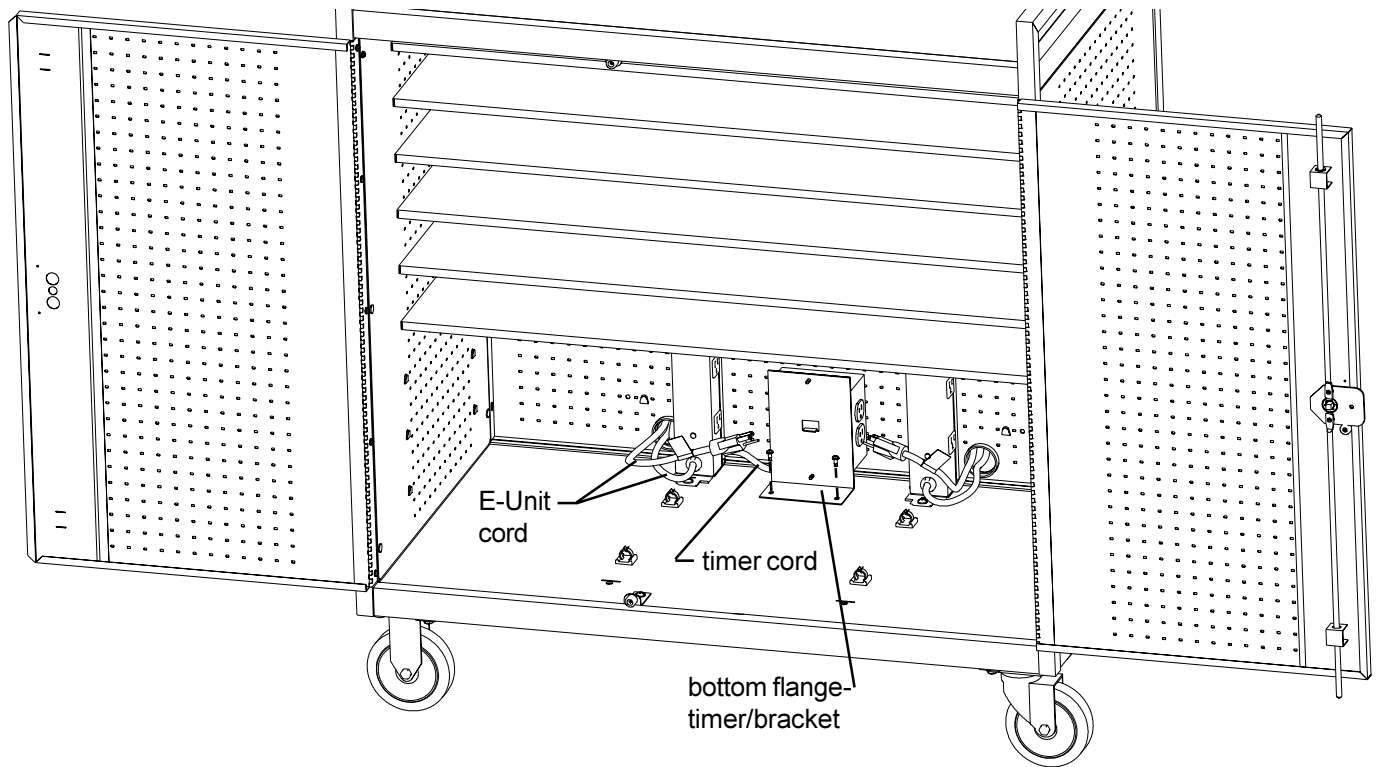

### Step 6

Install timer/bracket assembly onto bottom, rear of cart with 2 screws (into bottom flange of timer bracket). Make sure timer face is aligned with rear panel cutouts. Tighten screws. Feed the power cord from the timer out the grommeted hole shown. Unwind enough E-Unit power cord from the cord brackets on the rear panel to feed back through each grommeted hole and into the timer. Plug one E-Unit power cord into the bottom outlet of the timer marked 'A' only and the other E-Unit power cord into the bottom outlet of the timer marked 'B' only. **DO NOT PLUG BOTH E-UNIT POWER CORDS INTO ONE SIDE MARKED 'A' OR 'B' OUTLETS. THIS WILL CAUSE AN OVER LOAD DURING THE CHARGING PROCESS.**

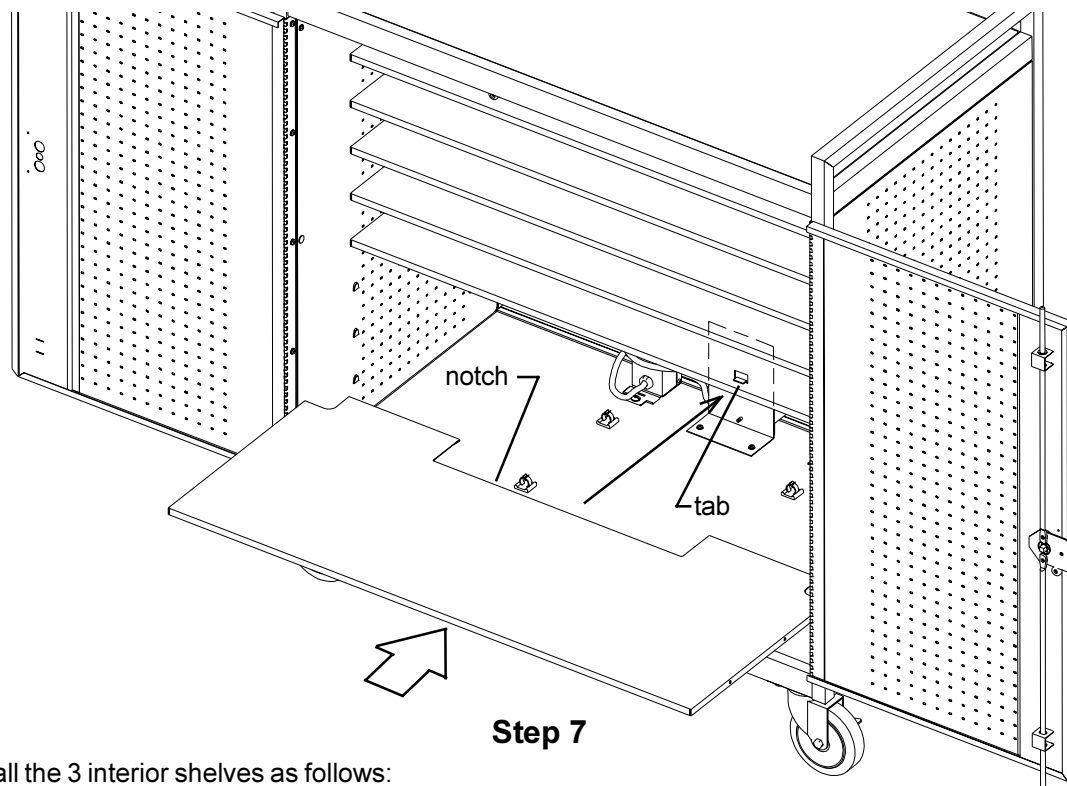

### Step 7

Reinstall the 3 interior shelves as follows:

1. Carefully slide in the shelf with notch at the **bottom** position (the notch will rest on the bracket tab). (Make sure that the shelf flanges are ALL seated into the mounting tabs.)
2. Slide in remaining 2 shelves into position as the bottom shelf.

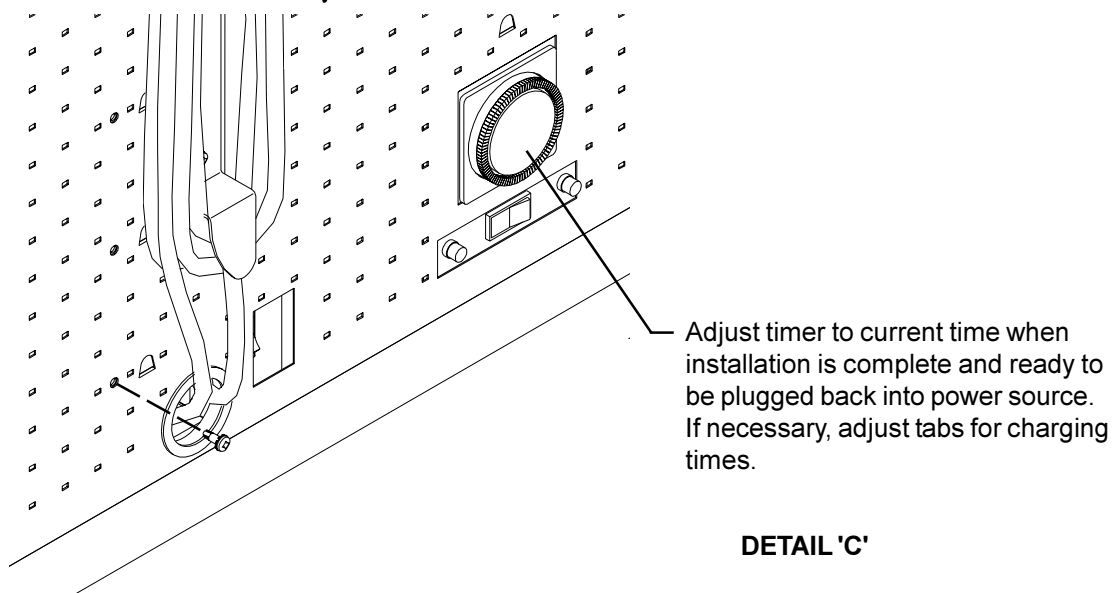
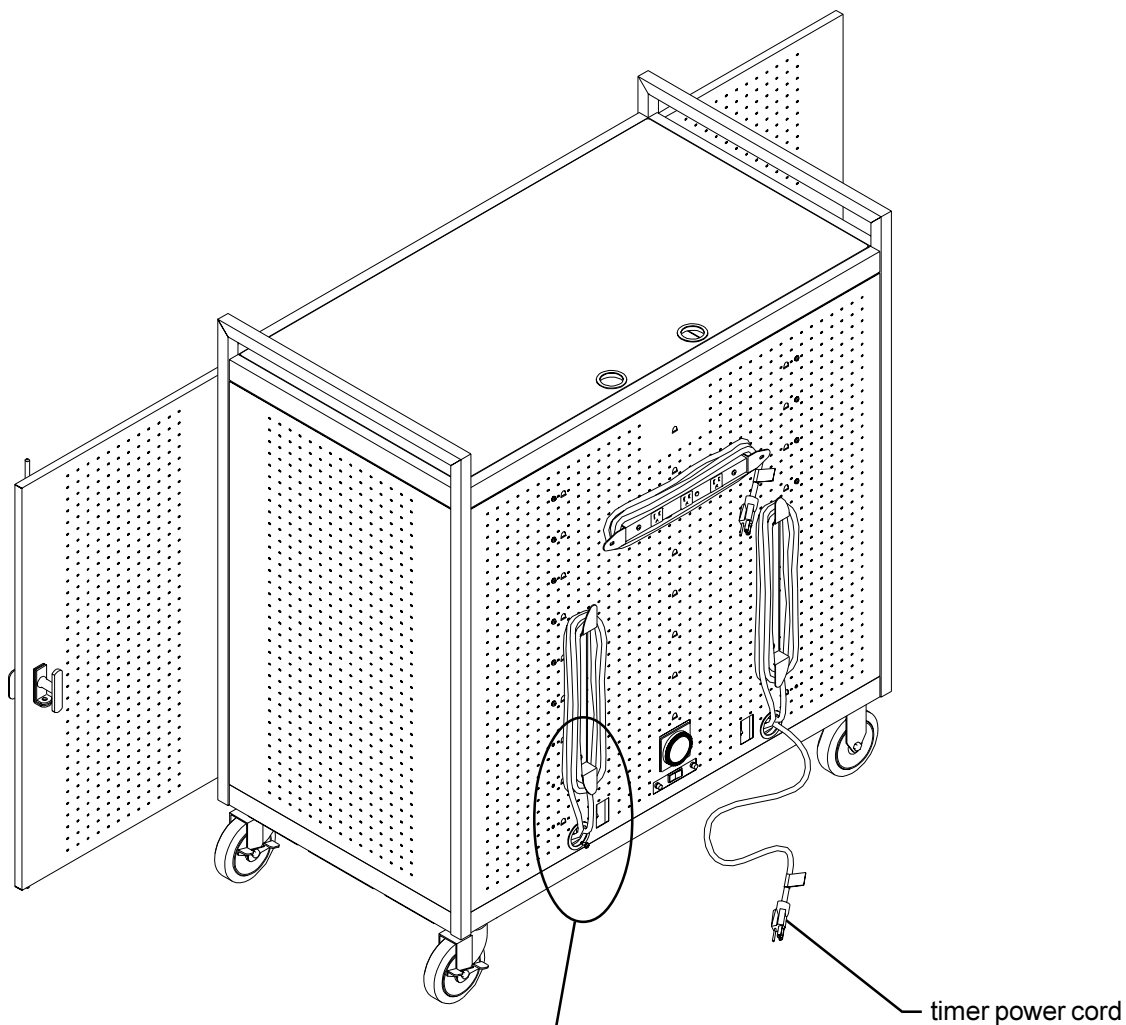

**DETAIL 'C'**

### **Step 8**

Reinstall 6 screws to rear panel that will secure the 3 interior shelves (see DETAIL 'C'). **DO NOT OVER TIGHTEN SCREWS.**

Installation is now complete and ready for use.



**NOTE:**

**UNPLUG CART POWER CORDS FROM  
POWER SOURCE BEFORE STARTING**

**TIMER INSTALLATION:  
'E-UNIT AT FRONT LOCATION'**

*Please read and follow all instructions thoroughly. Bretford will not be held responsible for improper installation or misuse of the timer unit.*

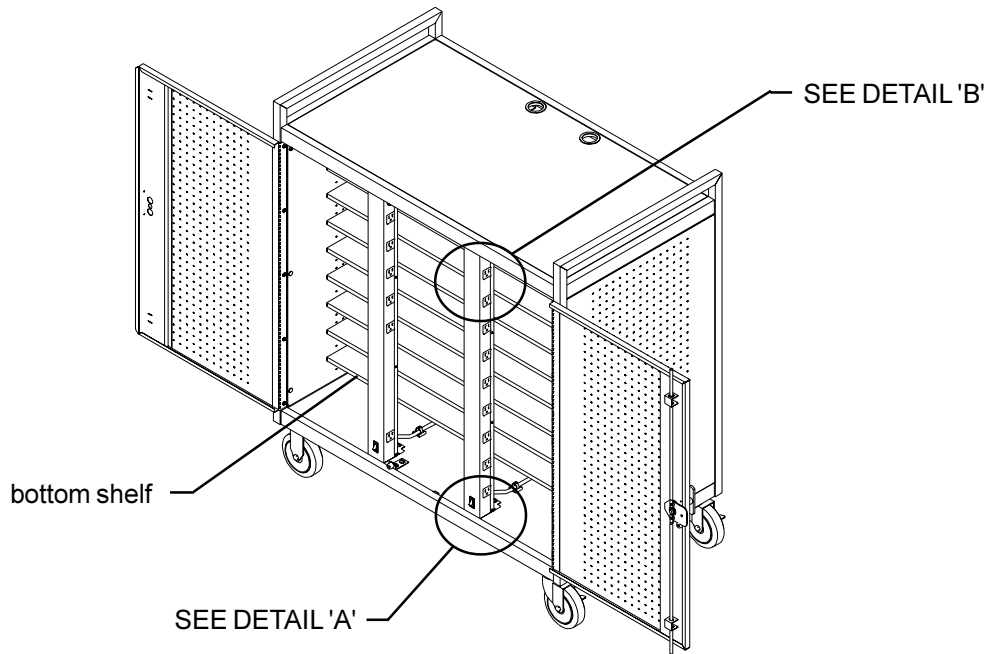

**Step 1**

Open both front doors of cart to access E-Units. Unwind any length of E-Unit power cord remaining on the back panel cord wrap brackets. Unclip the power cords from the side panel clips (see DETAIL 'A'). Loosen the screw holding the E-Unit bracket assembly and remove all 4 bracket assemblies (see DETAILS 'A' and 'B').

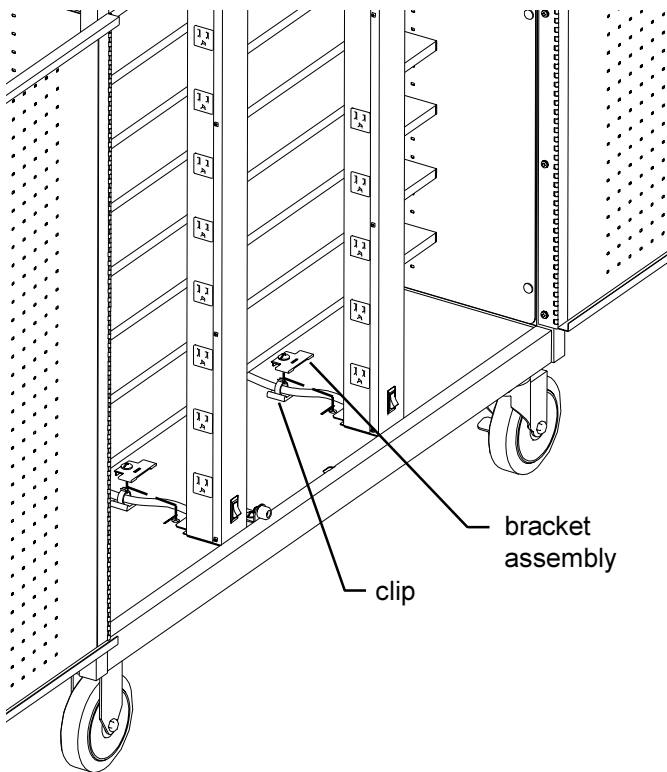

**DETAIL 'A'**

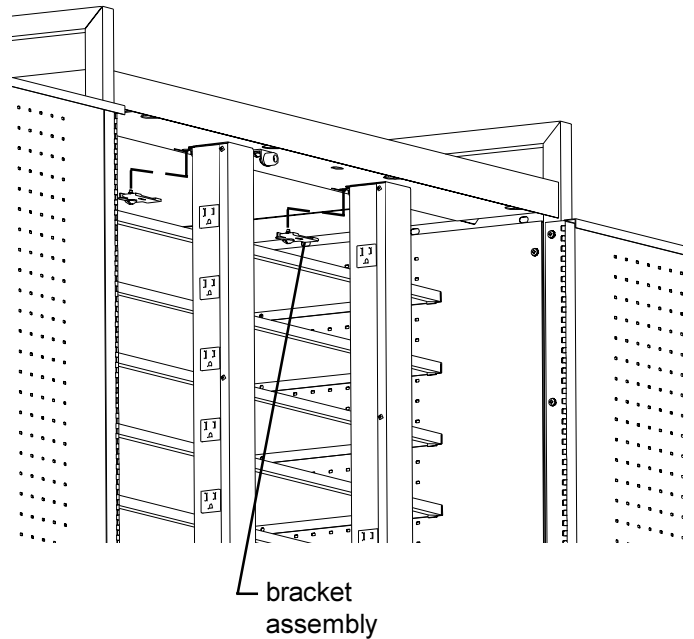

**DETAIL 'B'**

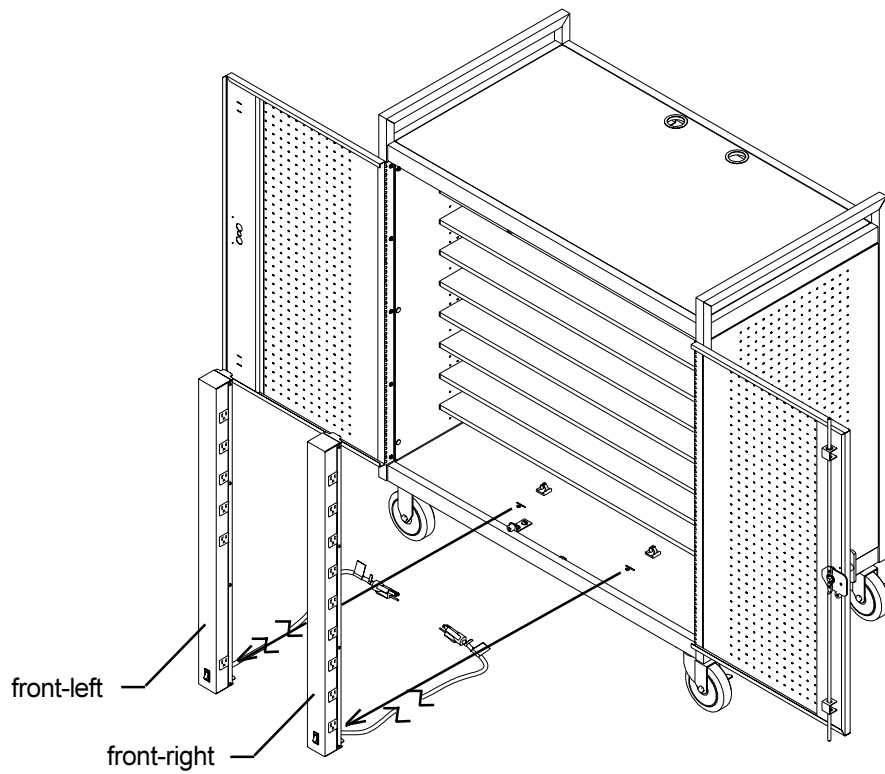

### Step 2

Remove **front-left** E-Unit by gripping the top and tilt it side ways until it clears the underside of the cart interior shelf channel and set it aside.

Remove **front-right** E-Unit by gripping the top and tilt it side ways until it clears the underside of the cart interior shelf channel and set it aside.

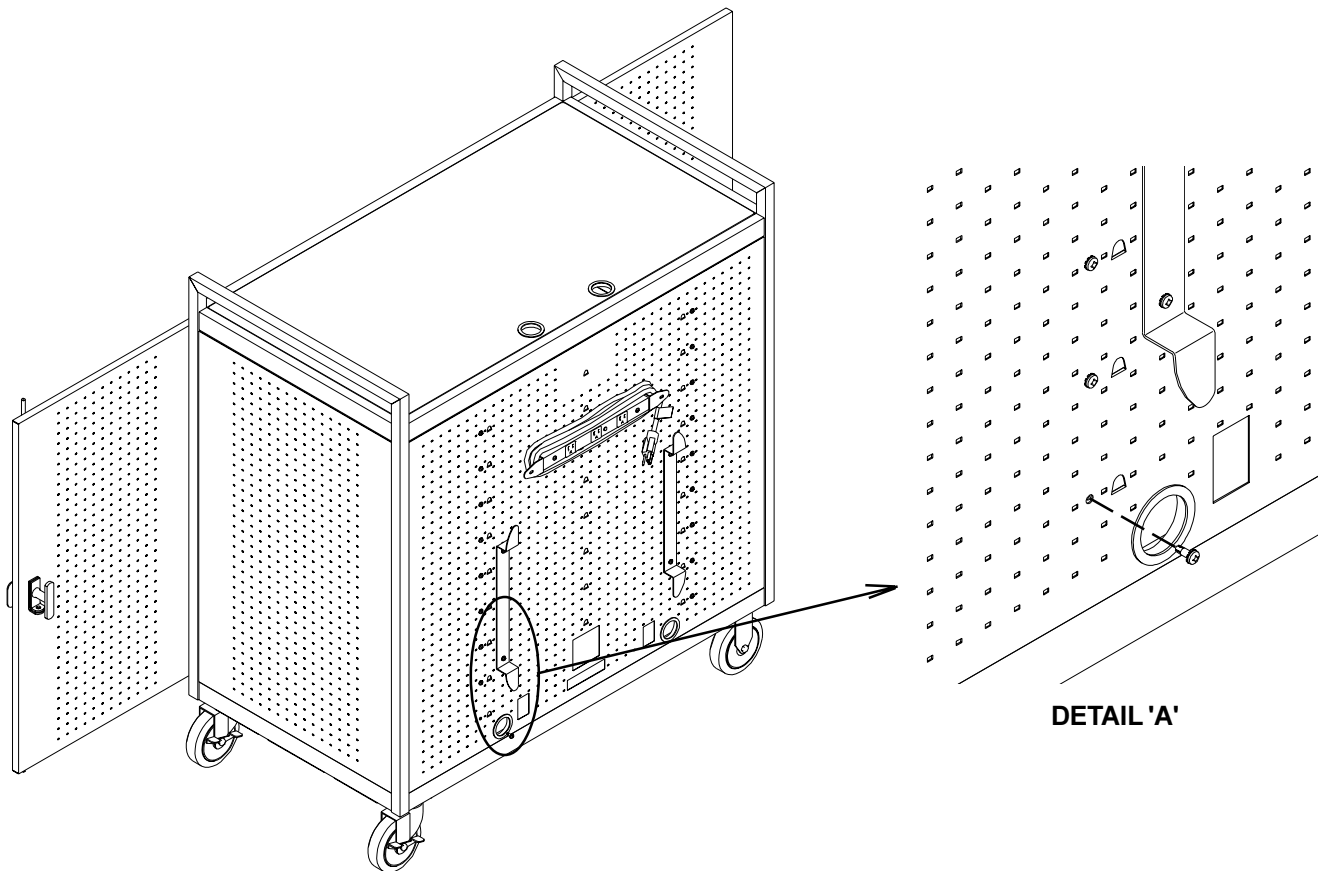

### Step 3

Remove 6 screws (2 per shelf) from rear panel that secure the 3 **bottom** interior shelves (see DETAIL 'A').

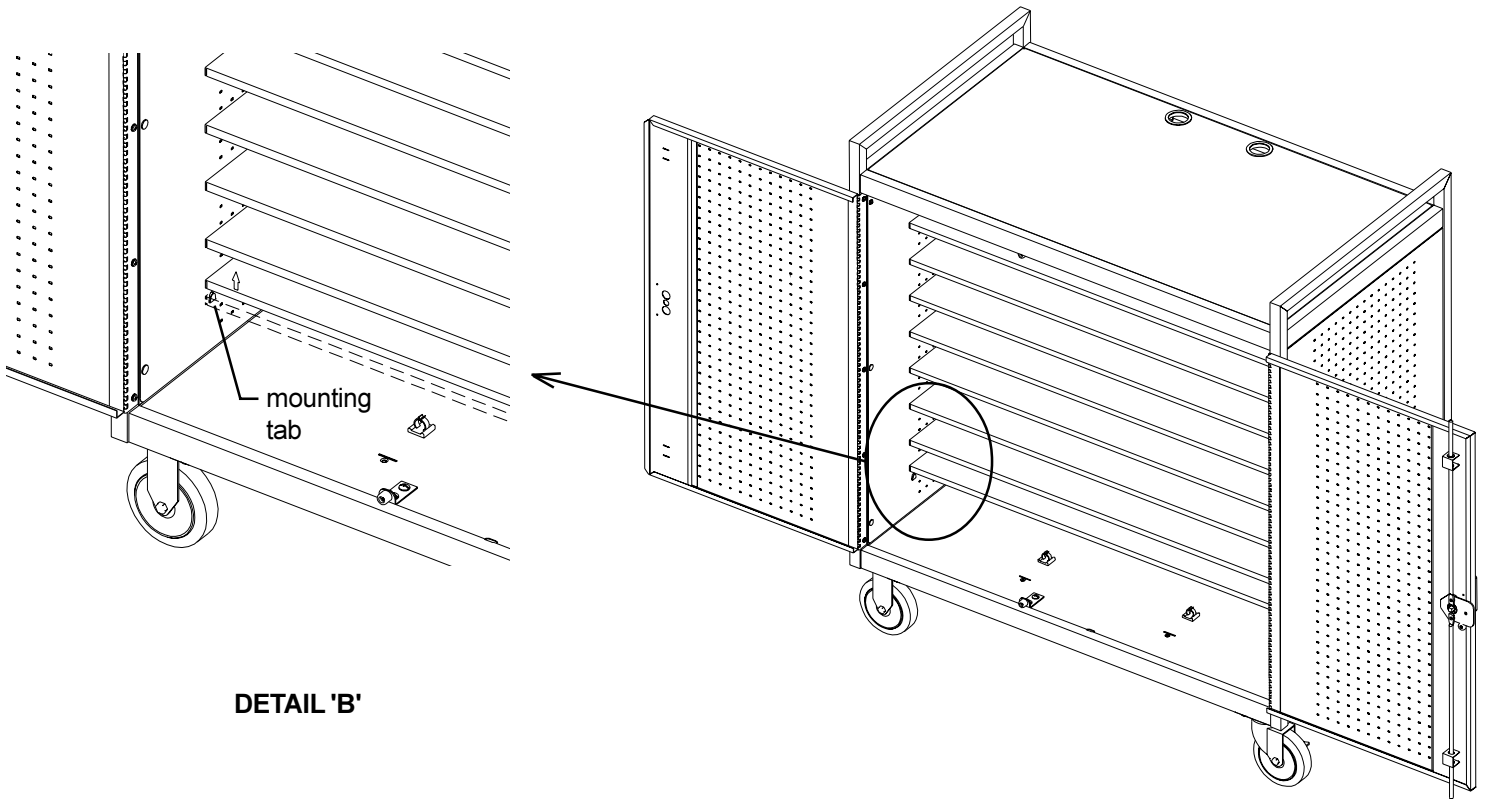

**DETAIL 'B'**

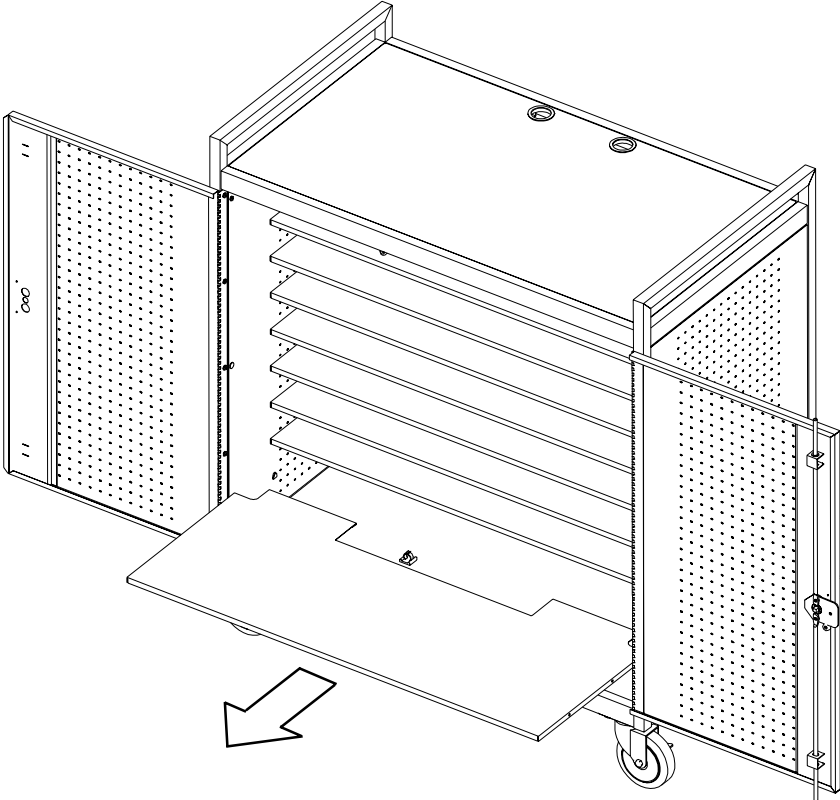

**Step 4**

With both doors open, remove the 3 bottom interior shelves by carefully pushing upward (to release shelf from mounting tabs) shown in Detail 'B', then carefully sliding out. Set each shelf aside.

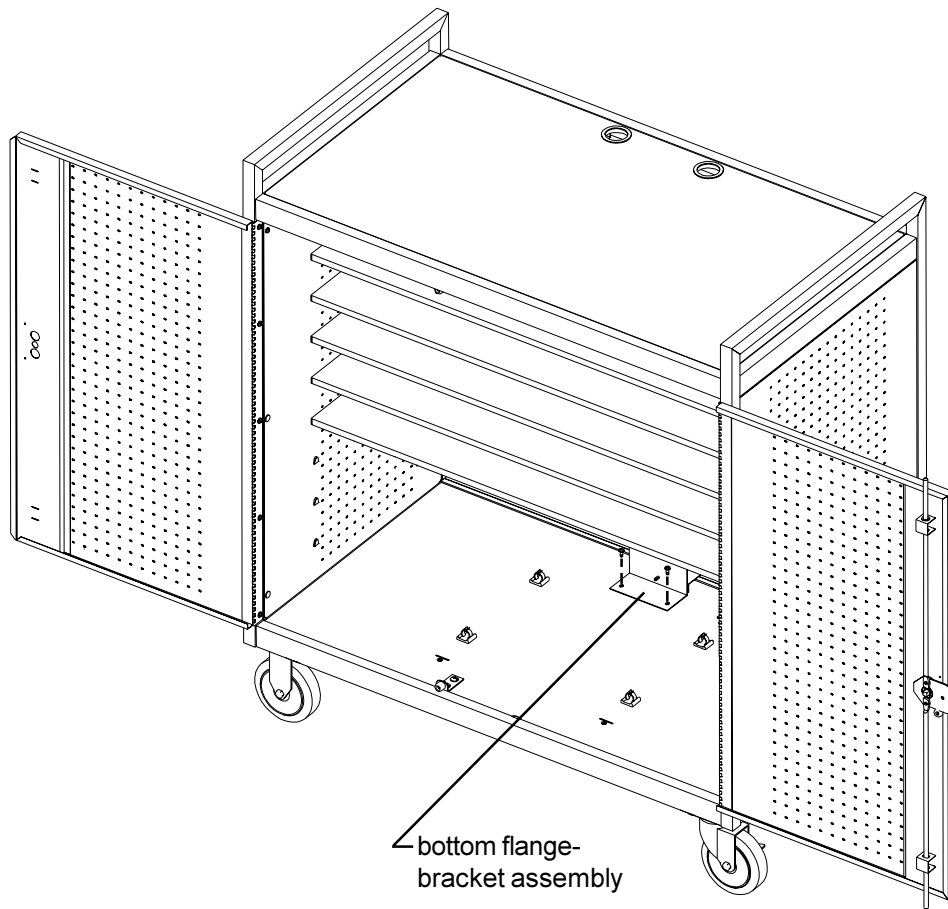

### Step 5

Remove 2 screws from bottom flange (securing bracket to bottom of cart) and remove bracket assembly.

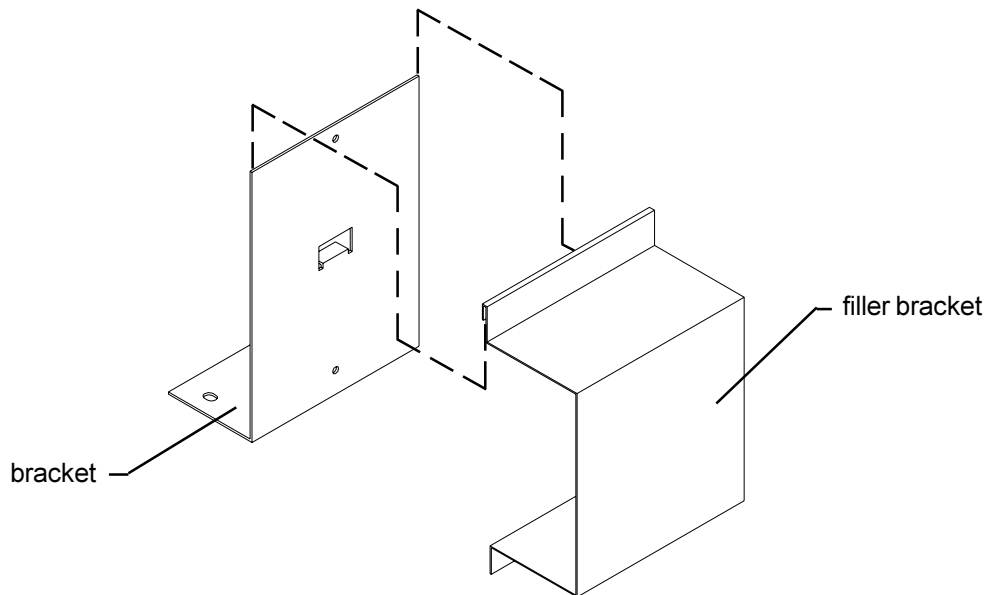

### Step 6

Remove filler bracket from bracket by pulling upward.  
Discard filler bracket.

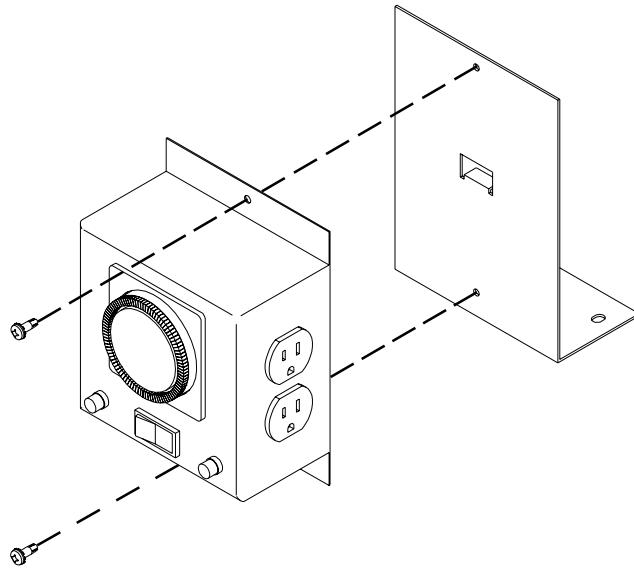

### Step 7

Install replacement timer with 2 screws. Adjust timer dial to current time.

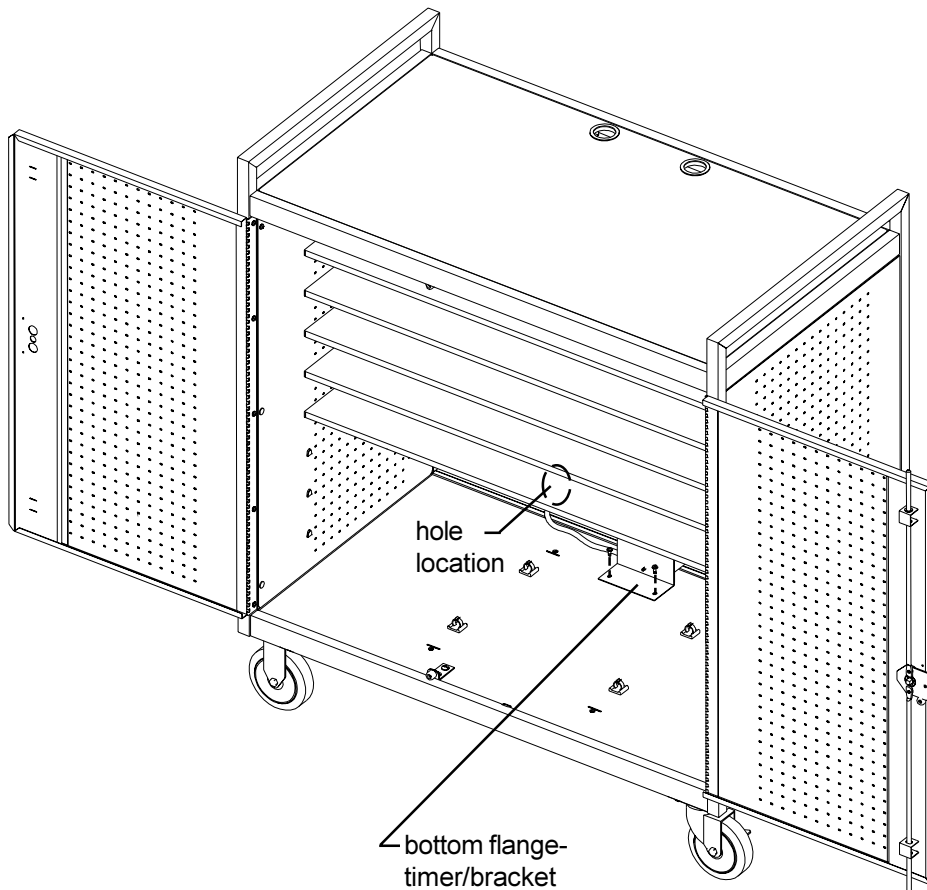

### Step 8

Install timer/bracket assembly onto bottom, rear of cart with 2 screws. Feed the power cord from the timer out the grommeted hole shown. Make sure timer face is aligned with rear panel cutouts. Tighten screws.

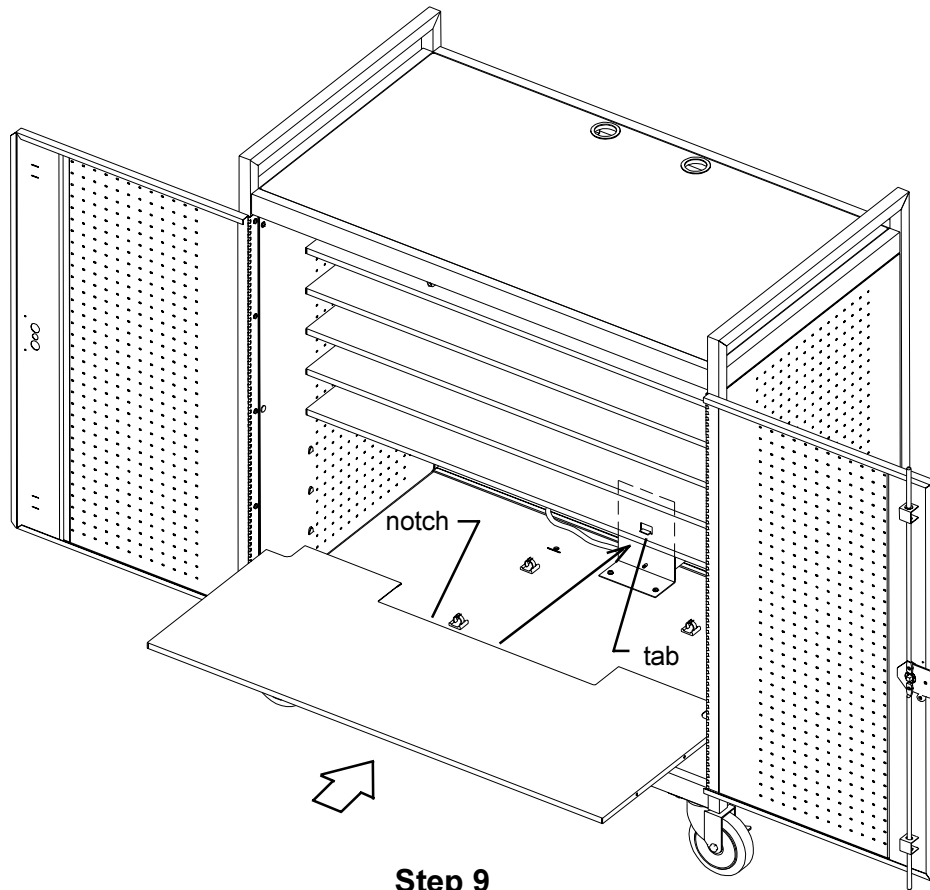

### Step 9

Reinstall the 3 interior shelves as follows:

1. Carefully slide in the shelf with notch at the **bottom** position (the notch will rest on the bracket tab). (Make sure that the shelf flanges are ALL seated into the mounting tabs.)
2. Slide in remaining 2 shelves into position as the bottom shelf.

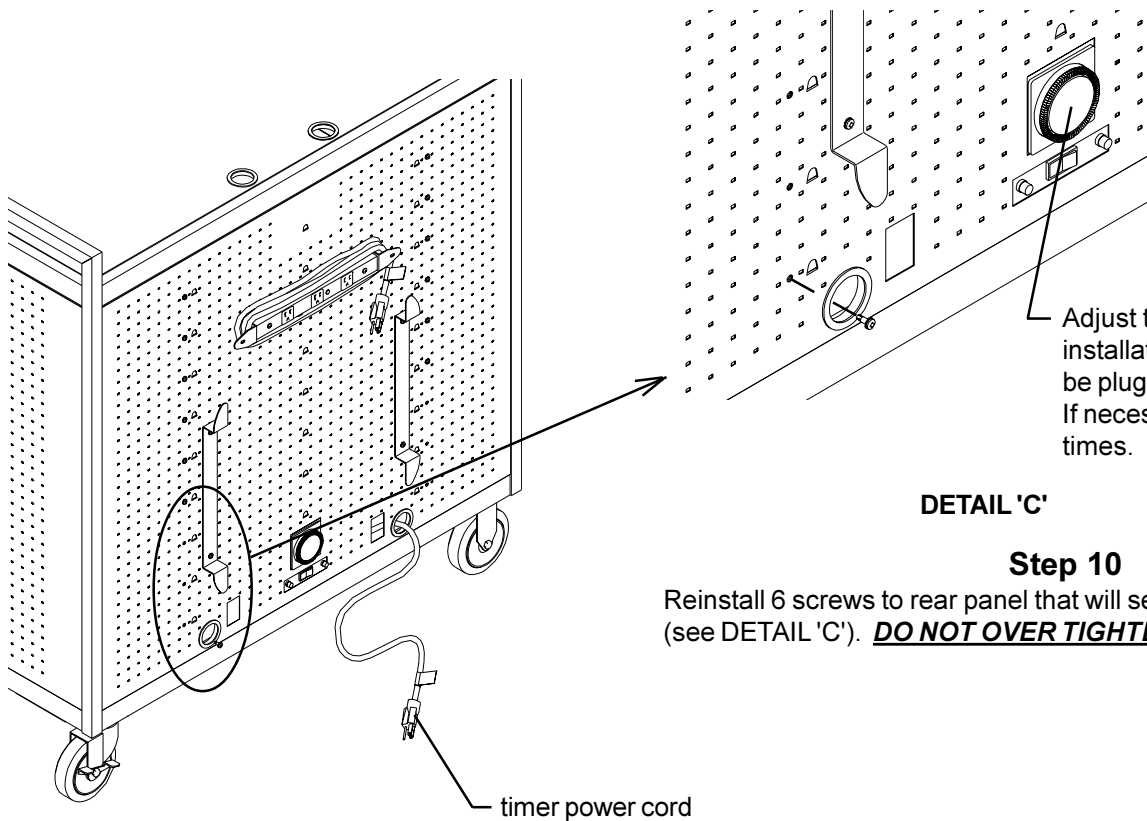

Adjust timer to current time when installation is complete and ready to be plugged back into power source. If necessary, adjust tabs for charging times.

### DETAIL 'C'

### Step 10

Reinstall 6 screws to rear panel that will secure the 3 interior shelves (see DETAIL 'C'). **DO NOT OVER TIGHTEN SCREWS.**

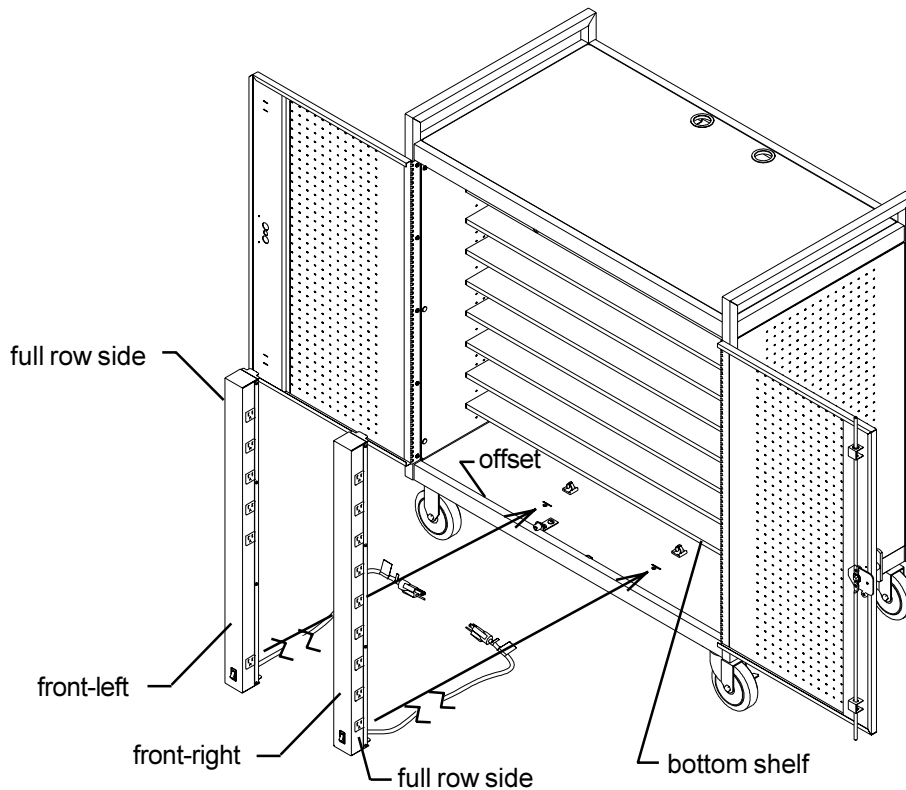

### Step 11

Carefully reinstall E-Units into position by placing bottom in first against the offset and tilting it in sideways to the top (underneath the channel bracket of the cart top panel).

When repositioned correctly, the E-Units power switch should face the front and the full row of outlets should face the door hinges.

Reinstall the E-Unit bracket assemblies (make sure that the top flange of the E-Unit is aligned with the slot in the bracket assembly) and tighten screws securely.

From underneath the bottom shelf, feed the E-Unit power cords (plug end) all the way through the bottom rear round grommets cutouts (next to bracket assembly).

Press each E-Unit power cord into the two wire clips located (in line, behind E-Unit) on the bottom of cart.

Wind power cords around the cord wrap bracket on the exterior rear panel for storage.

Unwind enough E-Unit power cord from the cord brackets on the rear panel to feed back through each grommets hole and into the timer. Plug one E-Unit power cord into the bottom outlet of the timer marked 'A' only and the other E-Unit power cord into the bottom outlet of the timer marked 'B' only.

**DO NOT PLUG BOTH E-UNIT POWER CORDS INTO ONE SIDE MARKED 'A' OR 'B' OUTLETS. THIS WILL CAUSE AN OVER LOAD DURING THE CHARGING PROCESS.**

Installation is now complete and ready for use.

# LABEL INSTALLATION:

peel off and attach corresponding labels to shelves and E-Units.

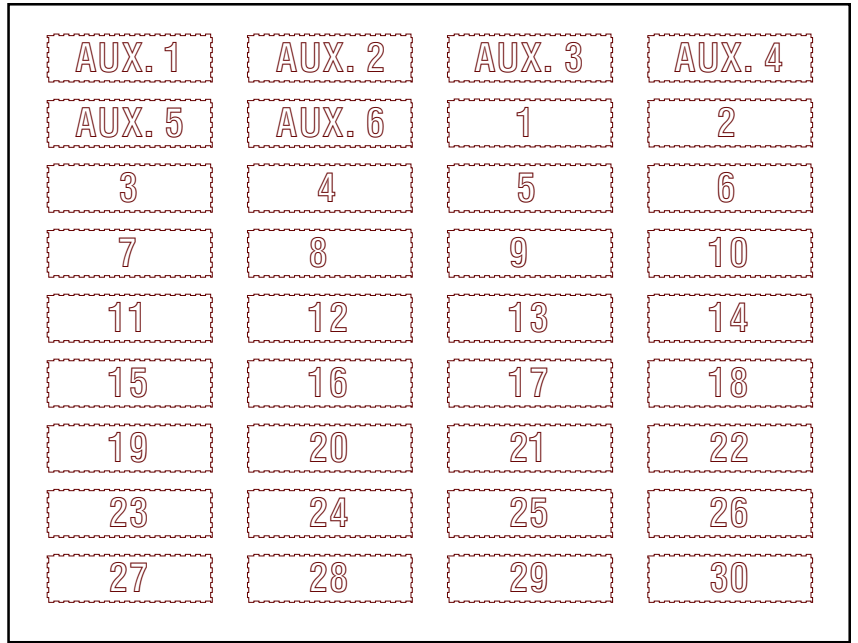

suggested installation of labels

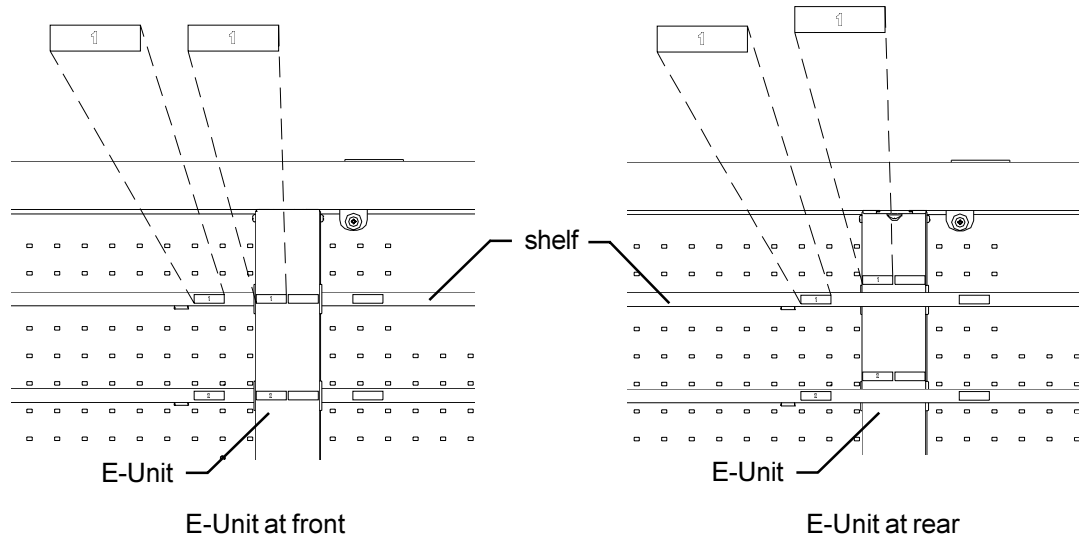

suggested label direction

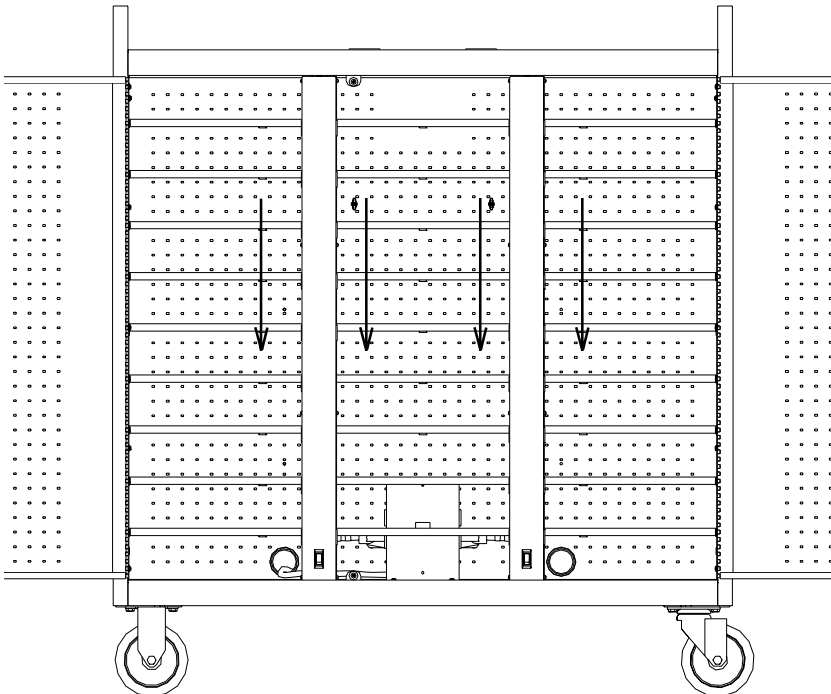



## PAD LOCK - DOOR:

### Resettable Combination Padlock

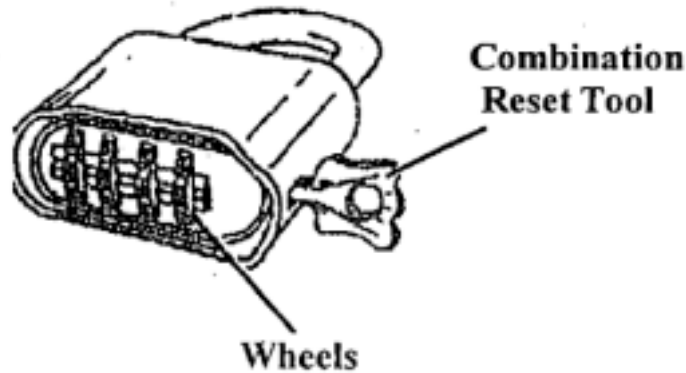

#### Open Lock The First Time

- 1) Set the combination to 0-0-0-0
- 2) Depress shackle and pull open.

#### To Set You Own Combination

- \*\*REMEMBER:** Combination can only be set when lock is open.
- 1) Insert "reset" tool (included in package) in hole on side of lock.
  - 2) Push key in and turn key 90 degrees in either direction.  
(Key automatically stays in this position).  
Failure to exert force while pushing key in will result in a failed attempt to set or reset combination.
  - 3) Set wheels to desired combination.
  - 4) Turn and remove reset tool. Lock is now set to new combination.  
**\*\*BE SURE TO RECORD YOUR COMBINATION.**
  - 5) To lock scramble the wheels and close the shackle.
  - 6) To reopen dial your combination and depress shackle.

**Bretford**  
11000 Seymour Avenue  
Franklin Park, IL 60131  
TEL: 847.678.2545  
800.521.9614  
FAX: 847.678.0852  
800.343.1779

**Bretford Ltd.**  
2 Etongate  
110 Winsor Road, Slough  
Berkshire SL1 2JA England  
TEL: 01753 539955  
FAX: 01753 539478

[www.bretford.com](http://www.bretford.com)

Part#031-6609  
Rev. 08.29.05 CH